

UNIT III KINEMATICS OF CAM MECHANISMS

INTRODUCTION

A cam is a mechanical device used to transmit motion to a follower by direct contact. The driver is called the cam and the driven member is called the follower. In a cam follower pair, the cam normally rotates while the follower may translate or oscillate. A familiar example is the cam shaft of an automobile engine, where the cams drive the push rods (the followers) to open and close the valves in synchronization with the motion of the pistons.

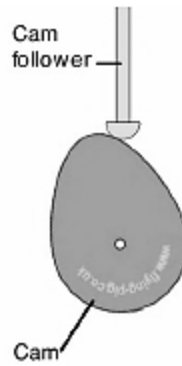

Cams:

Type of cams, Type of followers, Displacement, Velocity and acceleration time curves for cam profiles, Disc cam with reciprocating follower having knife edge, roller follower, Follower motions including SHM, Uniform velocity, Uniform acceleration and retardation and Cycloidal motion.

Cams are used to convert rotary motion into reciprocating motion. The motion created can be simple and regular or complex and irregular. As the cam turns, driven by the circular motion, the cam follower traces the surface of the cam transmitting its motion to the required mechanism. Cam follower design is important in the way the profile of the cam is followed. A fine pointed follower will more accurately trace the outline of the cam. This more accurate movement is at the expense of the strength of the cam follower.

Types of cams

Cams can be classified based on their physical shape.

a) Disk or plate cam The disk (or plate) cam has an irregular contour to impart a specific motion to the follower. The follower moves in a plane perpendicular to the axis of rotation of the cam shaft and is held in contact with the cam by springs or gravity.

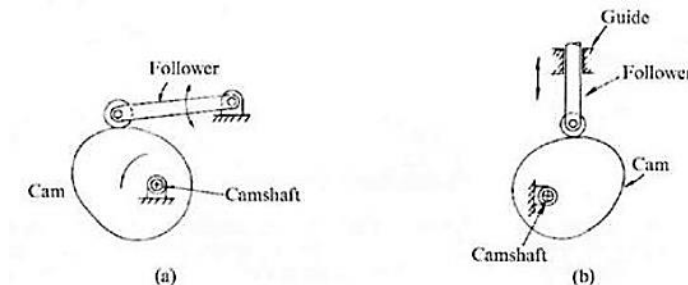

Fig 1 Plate or disk cam.

b)Cylindricalcam:The cylindrical cam has a groove cut along its cylindrical surface.The roller follows the groove, and the follower moves in a plane parallel to the axis of rotation of the cylinder.

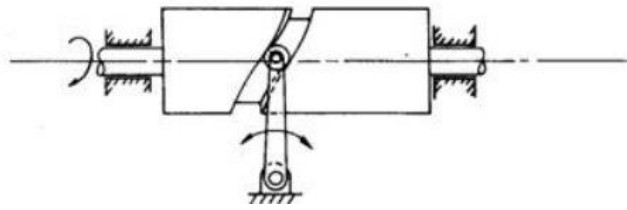

Fig. 2 Cylindrical cam.

c)Translating cam.The translating cam is a contoured or grooved plate sliding on a guiding surface(s).The follower may oscillate (Fig.3 a)or reciprocate (Fig. 3b).The contour or the shape of the groove is determined by the specified motion of the follower.

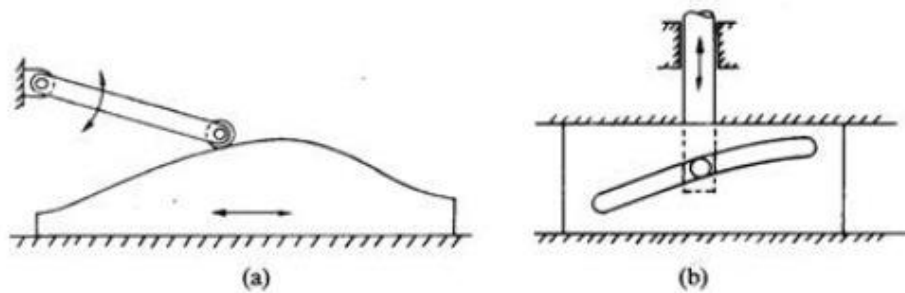
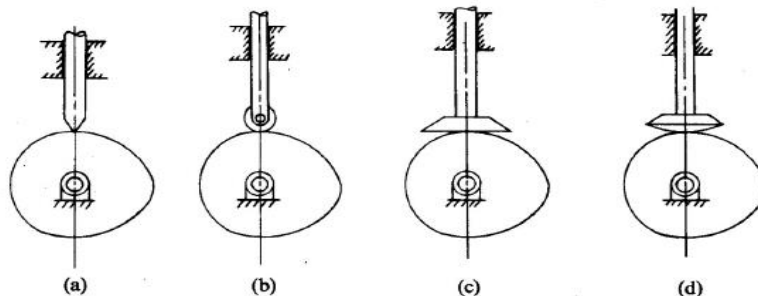

Fig. 3 translating cam

Types of followers

(i)Basedonsurfaceincontact.

- (a)Knifedgefollower
- (b)Rollerfollower
- (c)Flatfacedfollower
- (d)Sphericalfollower



(ii)Basedontypeofmotion

- (a)Oscillatingfollower
- (b)Translatingfollower

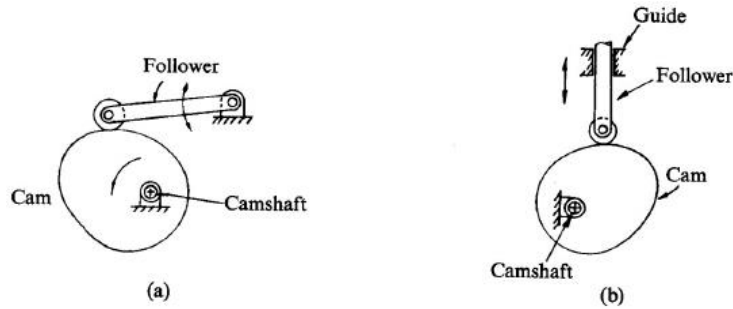

Based on line of motion

(a) Radial follower: The lines of movement of in-line cam followers pass through the centers of the camshafts

(b) Off-set follower: For this type, the lines of movement are off set from the centers of the Cam shafts

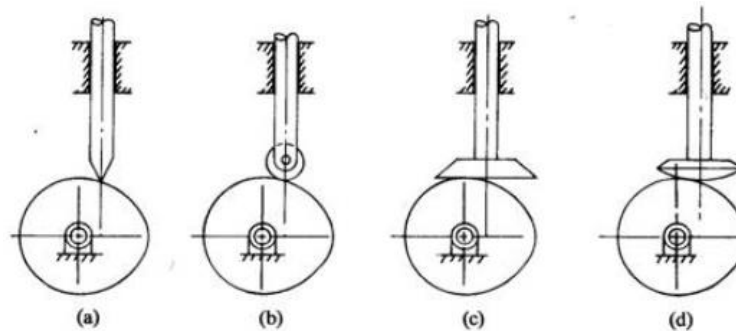

NOMENCLATURE OF CAMS

Cam Profile The contour of the working surface of the cam.

Trace Point The point at the knife edge of a follower, or the center of a roller, or the center of a spherical face.

Pitch Curve The path of the tracer point.

Base Circle The smallest circle drawn, tangential to the cam profile, with its center on the axis of the cam shaft. The size of the base circle determines the size of the cam.

Prime Circle The smallest circle drawn, that can be drawn from the center of the cam and tangent to the pitch curve.

Prime circle radius = Base circle radius for knife edge and flat faced follower

Prime circle radius = Base circle radius + radius of roller for roller follower

Pressure Angle The angle between the normal to the pitch curve and the direction of Motion of the follower at the point of contact

Lift of stroke: It is the maximum travel of the follower from its lowest position to the topmost position. The maximum rise is called lift

Pitch Point: It is a point on the curve having maximum pressure angle

Pitch Circle: It is the circle drawn from the center of the cam through the pitch points

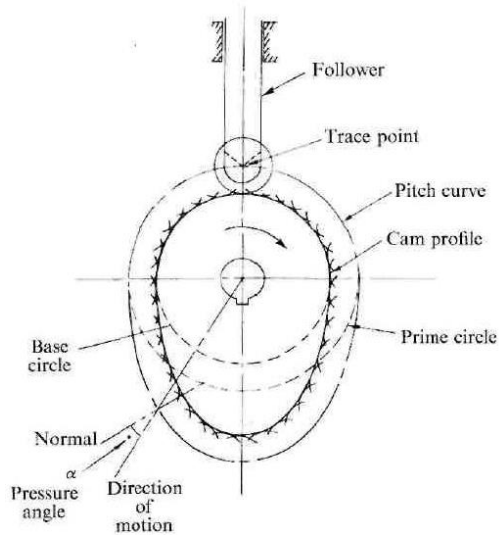

Fig. 7: Cam nomenclature

Types of follower motion:

Cam follower systems are designed to achieve a desired oscillatory motion. Appropriate displacement patterns are to be selected for this purpose, before designing the cam surface. The cam is assumed to rotate at a constant speed and the follower raises, dwells, returns to its original position and dwells again through specified angles of rotation of the cam, during each revolution of the cam. Some of the standard follower motions are as follows:

They are, follower motion with,

- (a) Uniform velocity
- (b) Modified uniform velocity
- (c) Uniform acceleration and deceleration
- (d) Simple harmonic motion
- (e) Cycloidal motion

Displacement diagrams:

In a cam follower system, the motion of the follower is very important. Its displacement can be plotted against the angular displacement θ of the cam and it is called as the displacement diagram. The displacement of the follower is plotted along the y-axis and angular displacement θ of the cam is plotted along the x-axis. From the displacement diagram, velocity v and acceleration a of the follower can also be plotted for different angular displacements θ of the cam. The displacement, velocity and acceleration diagrams are plotted for one cycle of operation i.e., one rotation of the cam. Displacement diagrams are basic requirements for the construction of cam profiles. Construction of displacement diagrams and calculation of velocities and accelerations of followers with different types of motions are discussed in the following sections.

(a) Follower motion with Uniform velocity:

Fig. 3.8 shows the displacement, velocity and acceleration patterns of a follower having uniform velocity type of motion. Since the follower moves with constant velocity, during rise and fall, the displacement varies

linearly with θ . Also, since the velocity changes from zero to a finite value, with in no time, theoretically, the acceleration becomes infinite at the beginning and end of rise and fall.

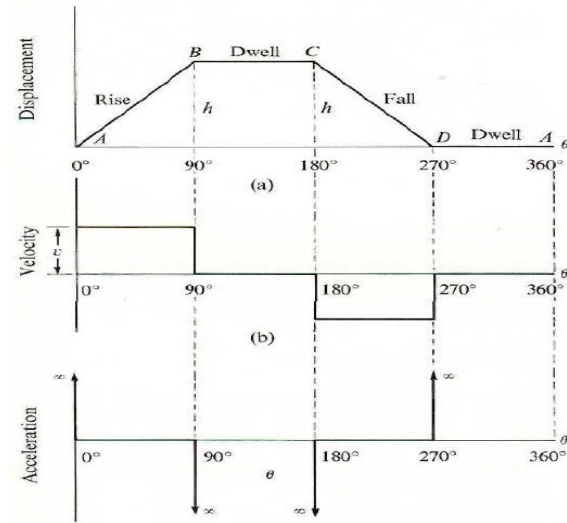

Follower motion with modified uniform velocity:

It is observed in the displacement diagrams of the follower with uniform velocity that the acceleration of the follower becomes infinite at the beginning and ending of rise and return strokes. In order to prevent this, the displacement diagrams are slightly modified. In the modified form, the velocity of the follower changes uniformly during the beginning and end of each stroke. Accordingly, the displacement of the follower varies parabolically during the periods. With this modification, the acceleration becomes constant during the periods, instead of being infinite as in the uniform velocity type of motion. The displacement, velocity and acceleration patterns shown in fig 9

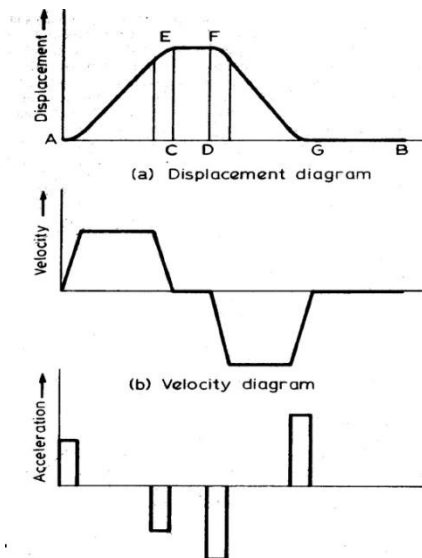

b) Simple Harmonic Motion: In fig 10, the motion executed by point P, which is the projection of point P on the vertical diameter is called simple harmonic motion. Here, P moves with uniform angular velocity ω_p , along a circle of radius r ($r = s/2$).

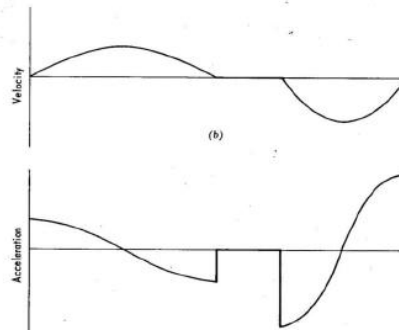
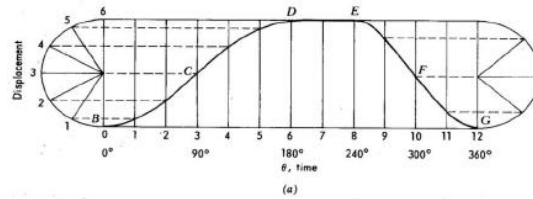

(c) Cycloidal motion:

Cycloid is the path generated by a point on the circumference of a circle, as the circle rolls without slipping, on a straight/flat surface. The motion executed by the follower here, is similar to that of the projection of a point moving along a cycloidal curve on a vertical lines shown in figure. 11

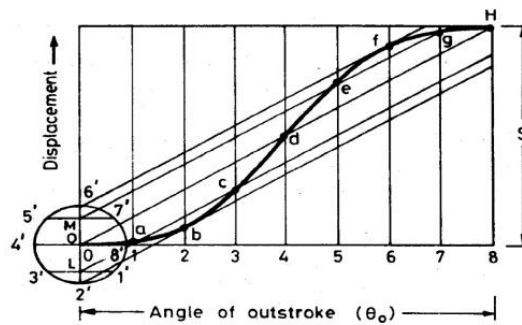
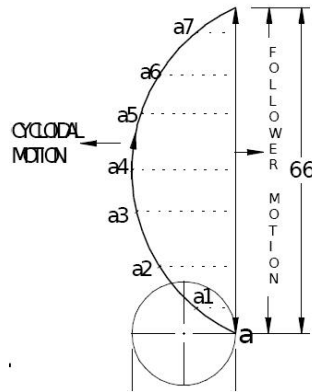

(a) Displacement diagram

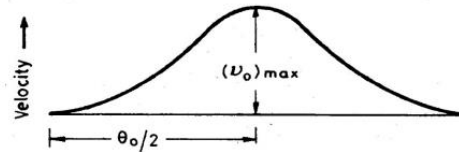

(b) Velocity diagram

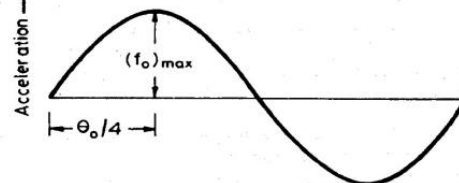

(c) Acceleration diagram

Draw the camprofile for following conditions:

Follower type = Knife edged,in-line; lift = 50mm; base circle radius = 50mm; outstroke with SHM,for 60°cam rotation; dwell for 45°cam rotation; return stroke with SHM, for 90° cam rotation; dwell for the remaining period. (2) Draw the cam profile for the same operating condition so f with the follower offset by 10mm to the left of cam center.

Displacement diagram:

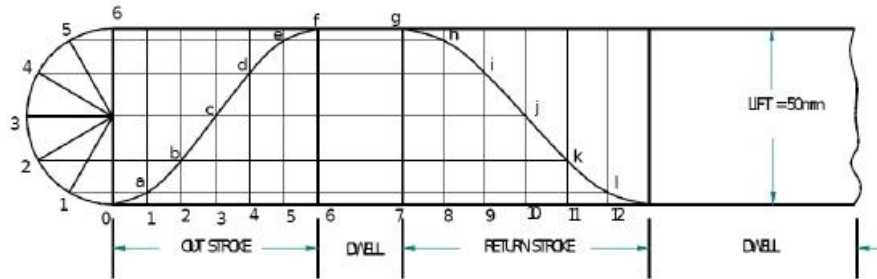
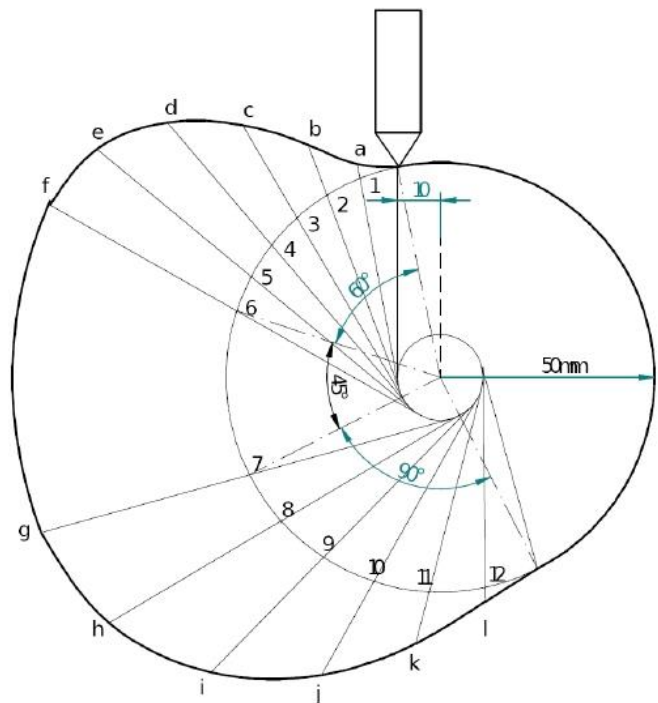
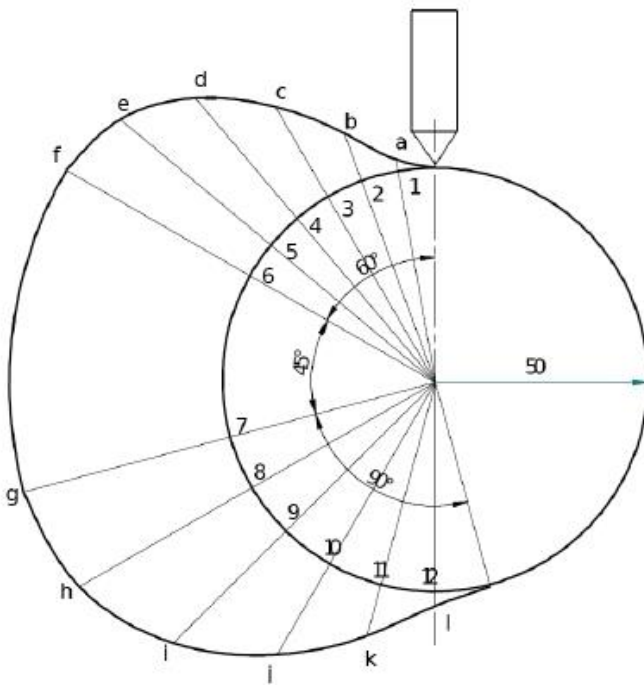

Fig 12

Cam profile:



Cam profile with 10 mm offset:

Draw the cam profile for following conditions:

Follower type=roller follower, in-line; lift=25mm; base circle radius = 20mm; roller radius = 5mm; out stroke with Uniform acceleration and retardation, for 120° cam rotation; dwell for 60° cam rotation; return stroke with Uniform acceleration and retardation, for 90° cam rotation; dwell for the remaining period. Draw the cam profile for conditions same with follower off set to right of cam center by 5mm and cam rotating counter clockwise.

DisplacementDiagram:

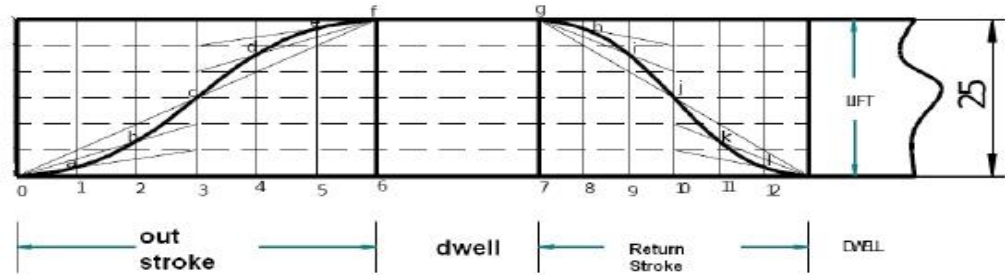

Cam profile:

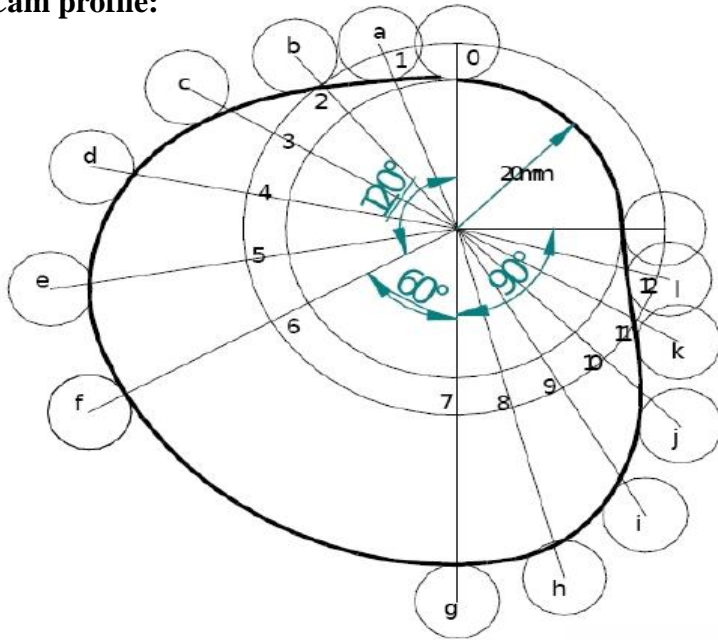

Cam profile with 5 mm offset

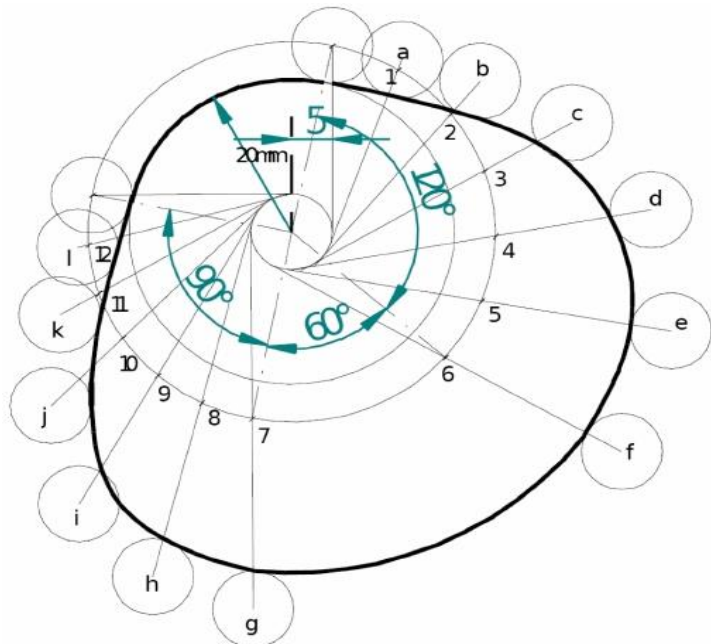

Draw the cam profile for following conditions:

Follower type=knife edge d follower, in line; lift=30mm;base circle radius =20mm;outstroke with uniform velocity in 120°of cam rotation;dwell for 60°; return stroke with uniform velocity, during 90°of cam rotation; dwell for the remaining period.

DisplacementDiagram

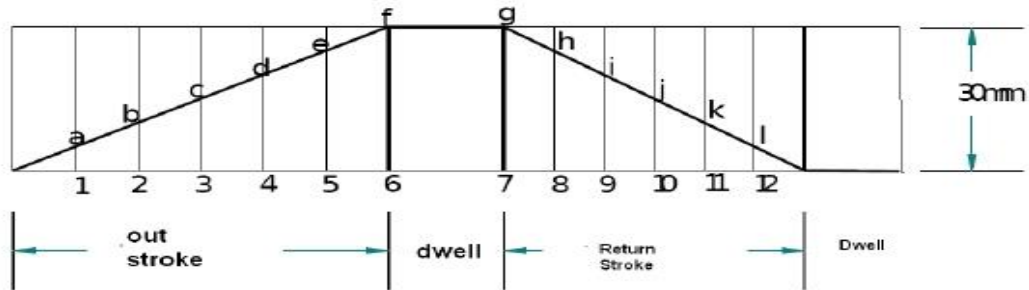

Cam profile

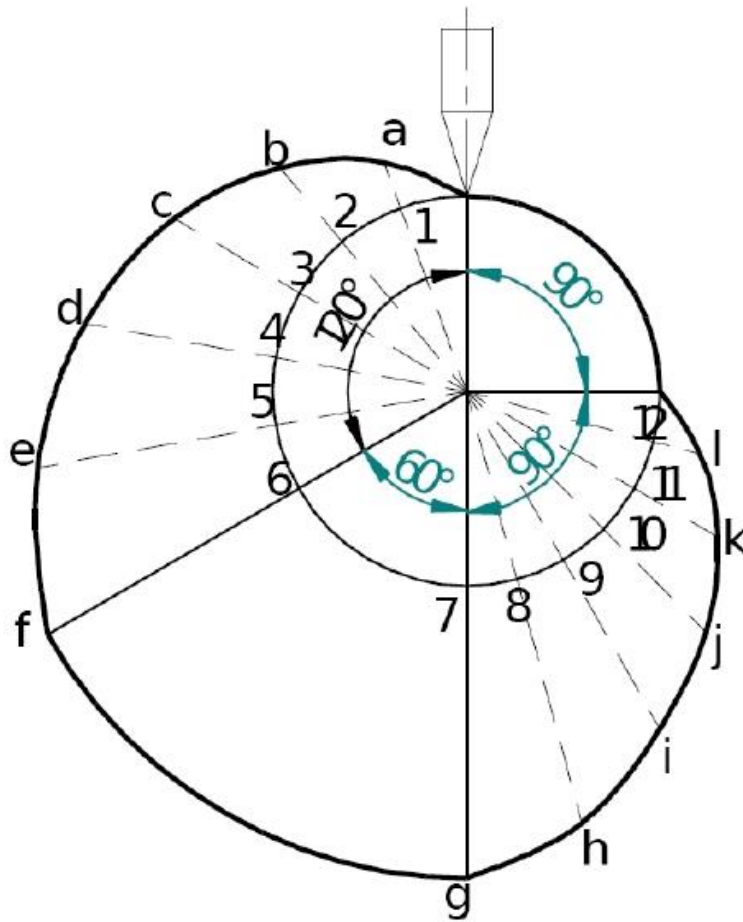

Drawthecamprofileforfollowingconditions:

Follower type = flat faced follower, inline; follower rises by 20mm with SHM in 120° of cam rotation, dwells for 30° of cam rotation; returns with SHM in 120° of cam rotation and dwells during the remaining period. Base circle radius =25mm.

Displacement Diagram:

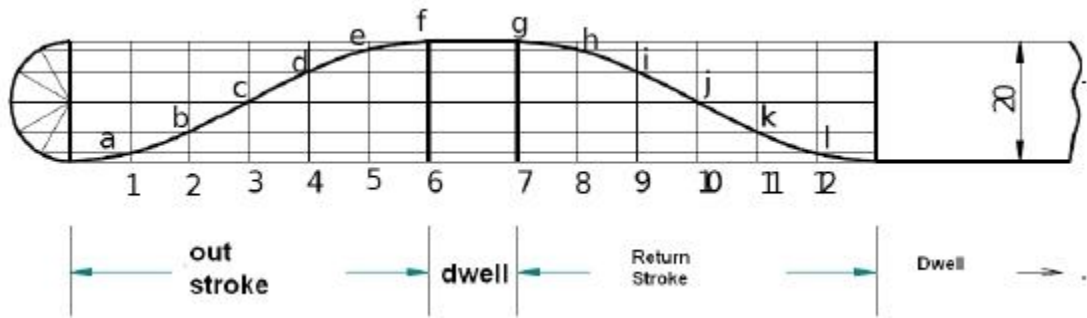

Cam profile

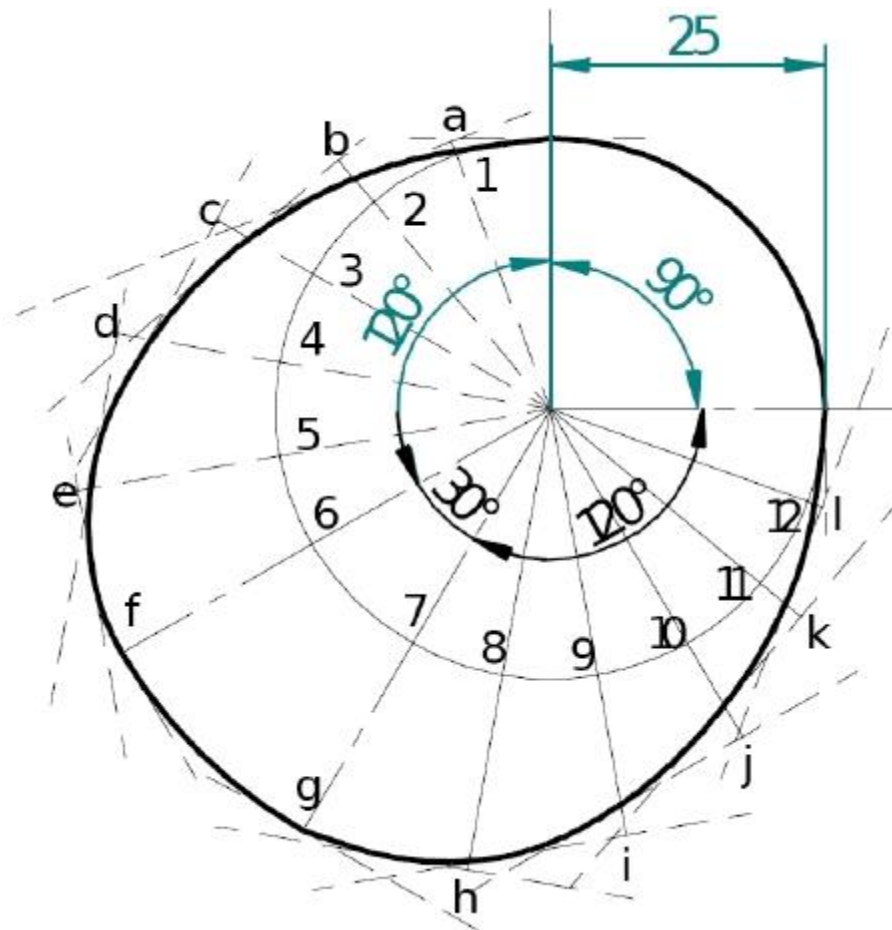

Layout of plate cam profiles:

- Drawing the displacement diagrams for the different kinds of the motions and the plate cam profiles for these different motions and different followers.
- SHM, Uniform velocity, Uniform acceleration and retardation and Cycloidal motions
- Knife-edge, Roller, Flat-faced and Mushroom followers.

Derivatives of Follower motion:

- Velocity and acceleration of the followers for various types of motions.
- Calculation of Velocity and acceleration of the followers for various types of motions.

Circular arc and Tangent cams:

- Circular arc
- Tangent cam

Standard cam motion:

- Simple Harmonic Motion
- Uniform velocity motion
- Uniform acceleration and retardation motion
- Cycloidal motion

Pressure angle and undercutting:

- Pressure angle
- Undercutting

A cam, with a minimum radius of 25 mm, rotating clockwise at a uniform speed is to be designed to give a roller follower, at the end of a valve rod, motion described below:

1. To raise the valve through 50 mm during 120° rotation of the cam:
2. To keep the valve fully raised though next 30°.
3. To lower the valve during next 60° and
4. To keep the valve closed during rest of the revolution i.e. 150°

The diameter of the roller is 20 mm and the diameter of the cam shaft is 25 mm. Draw the profile of the cam when

1. The line of stroke of the valve rod passes through the axis of the cam, and
2. The line of stroke is offset 1.5 mm from the axis of the cam shaft.

The displacement of the valve, while being raised and lowered, is to take place with simple harmonic motion. Determine the maximum acceleration of the valve rod when the cam shaft rotated at 100 r.p.m. Draw the displacement, velocity and the acceleration diagrams for one complete revolution of the cam.

Solution: Given: $S = 50 \text{ mm} = 0.05 \text{ m}$; $\theta_O = 120^\circ = 2 \times \pi/3 \text{ rad} = 2.1 \text{ rad}$; $\theta_R = 60^\circ = \pi/3 \text{ rad} = 1.047 \text{ rad}$; $N = 100 \text{ r.p.m}$

Profile of the cam when the line of stroke of the valve rod passes through the axis of the cam shaft

The profile of the cam, as shown in Fig, is drawn as discussed in the following steps:

- Draw a base circle with center O and radius equal to the minimum radius of the cam (i.e. 25 mm)
- Draw a prime circle with center O and radius,
- $OA = \text{Minimum radius of cam} + \frac{1}{2} \text{ Diameter of roller} = 25 + \frac{1}{2} \times 20 = 35 \text{ mm}$
- Draw angle $AOS = 120^\circ$ to represent raising or out stroke of the valve, angle $SOT = 30^\circ$ to represent dwell and angle $TOP = 60^\circ$ to represent lowering or return stroke of the valve.
- Divide the angular displacements of the cam during raising and lowering of the valve (i.e, angle AOS and TOP) into same number of equal even parts as in displacement diagram.
- Join the points 1, 2, 3, etc. with the centre O and produce the lines beyond prime circle as shown in Fig 22.
- Set off $1B, 2C, 3D$ etc. equal to the displacements from displacement diagram.
- Join the points A, B, C ... N, P, A. The curve drawn through these points is known as pitch curve.
- From the points A, B, C ... N, P, draw circles of radius equal to the radius of the roller.
- Join the bottom of the circles with a smooth curve as shown in fig 22. This is the required profile of the cam.

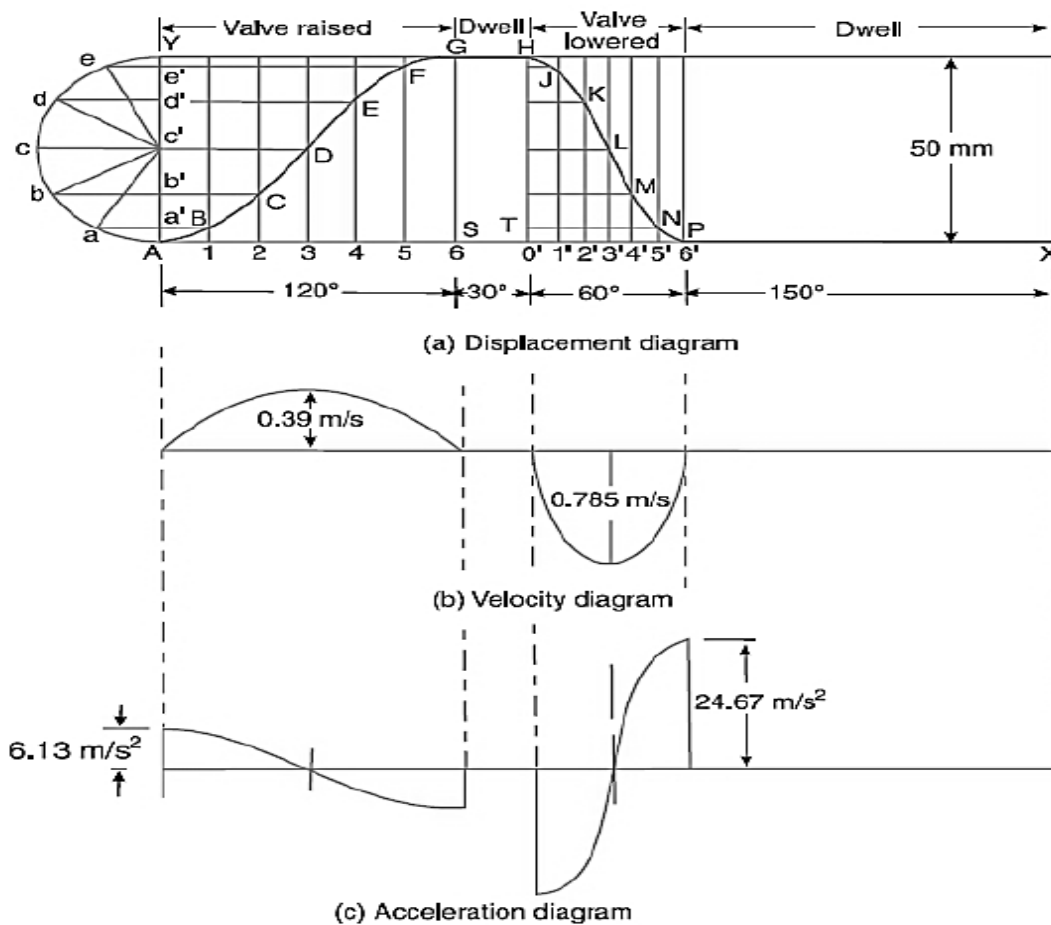

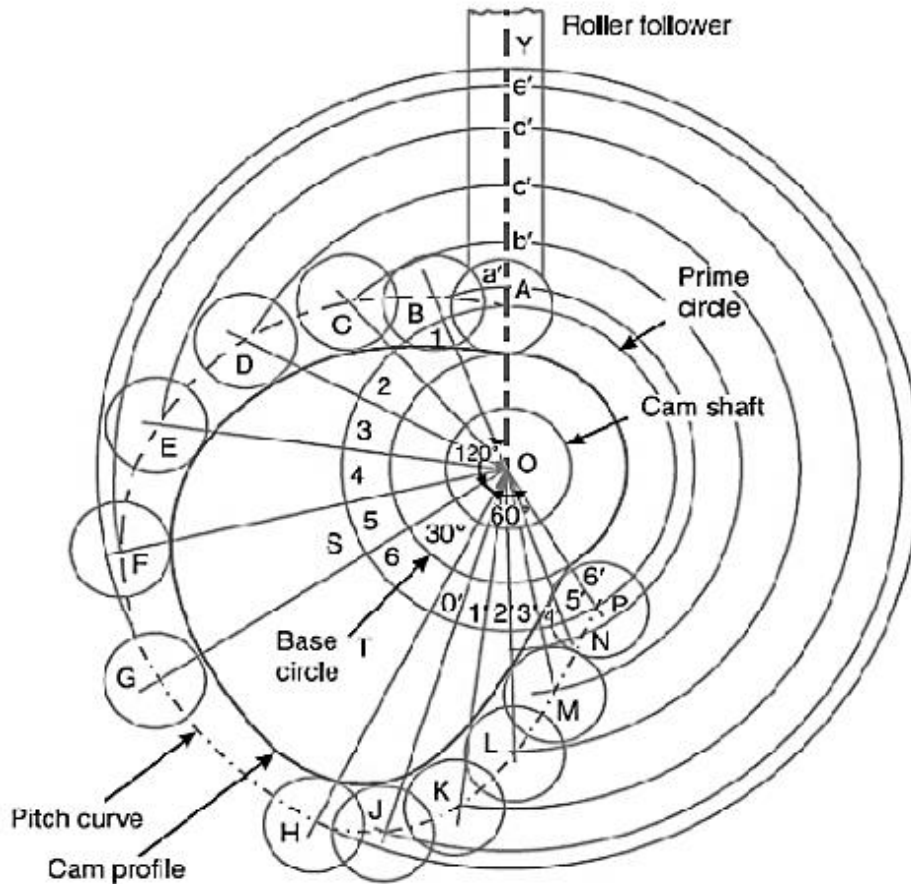

(a) profile of the cam when the line of stroke is offset 15 mm from the axis of the cam shaft:

The profile of the cam when the line of stroke is offset from the axis of the cam shaft, as shown in fig 24 may be drawn as discussed in the following steps:

- Draw a base circle with center O and radius equal to 25 mm.
- Draw a prime circle with center O and radius $OA = 35$ mm
- Draw an offset circle with center O and radius equal to 15 mm.
- Join OA. From OA draw the angular displacement of cam i.e. draw angle $AOS = 120^\circ$. Angle $SOT = 30^\circ$ angle $TOP = 60^\circ$
- Divide the angular displacements of the cam during raising and lowering of the valve into the same number of equal even parts (i.e. six parts) as in displacement diagrams.
- From points 1, 2, 3 Etc on the prime circle draw tangents to the offset circle.
- Set off 1B, 2C, 3D ... etc. equal to displacements as measured from the displacement diagram.
- By joining the points A, B, C ... M, N, P. with a smooth curve, we get pitch curve.
- Now A, B, C, etc. as center draw circles with a radius equal to the radius of roller.
- Join the bottoms of the circles with a smooth curve as shown in fig 24. This is the required profile of the cam.

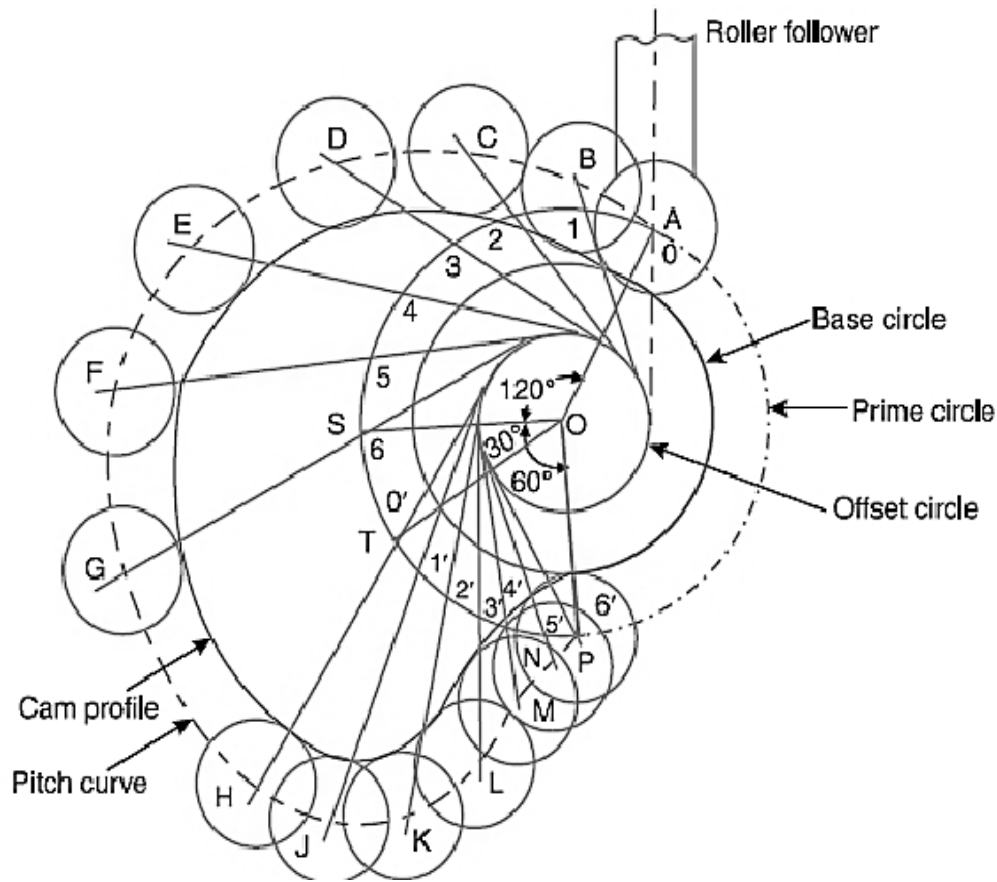

Maximum acceleration of the valve rod

We know that angular velocity of the cam shaft.

$$\omega = 2\pi N/60 = 2\pi \times 100/60 = 10.47 \text{ rad/s}$$

We also know that maximum velocity of the valve rod to raise valve.

$$V_O = \pi \omega S/2\theta_O = \pi \times 10.47 \times 0.05/2 \times 2.1 = 0.39 \text{ m/s}$$

And maximum velocity of the valve rod to lower the valve.

$$V_R = \pi \omega S/2\theta_R = \pi \times 10.47 \times 0.05/2 \times 1.047 = 0.785 \text{ m/s}$$

The velocity diagram for one complete revolution of the cam is shown fig 24

We know that the maximum acceleration of the valve rod to raise the valve.

$$a_O = \pi^2 \omega^2 S/2(\theta_O)^2 = \pi^2 \times (10.47)^2 \times 0.05/2 \times (2.1)^2 = 0.785 \text{ m/s}^2$$

and maximum acceleration of the valve rod to lower the valve,

$$a_R = \pi^2 \omega^2 S/2(\theta_R)^2 = \pi^2 \times (10.47)^2 \times 0.05/2 \times (1.047)^2 = 0.785 \text{ m/s}^2$$

A cam is to give the following motion to a KNIFE-EDGED FOLLOWER :

1. Outstroke during 60° of cam rotation ;
2. Dwell for the next 30° of cam rotation ;
3. Return stroke during next 60° of cam rotation, and
4. Dwell for the remaining 210° of cam rotation.

The stroke of the follower is 40 mm and the minimum radius of the cam is 50 mm. The follower moves with UNIFORM VELOCITY during both the outstroke and return strokes. Draw the profile of the cam when

- (a) the axis of the follower passes through the axis of the cam shaft, and
- (b) the axis of the follower is offset by 20 mm from the axis of the cam shaft.

Given:

Outstroke Angle = 60° (20mm)
 Dwell (Outstroke) Angle = 30° (10mm)
 Return Stroke angle = 60° (20mm)
 Dwell (Return Stroke) Angle = 210° (70mm)
 Stroke = 40mm
 Radius of CAM = 50mm
 Offset = 20mm

Assume
 $30^\circ = 10\text{mm}$
 $360^\circ = 120\text{mm}$

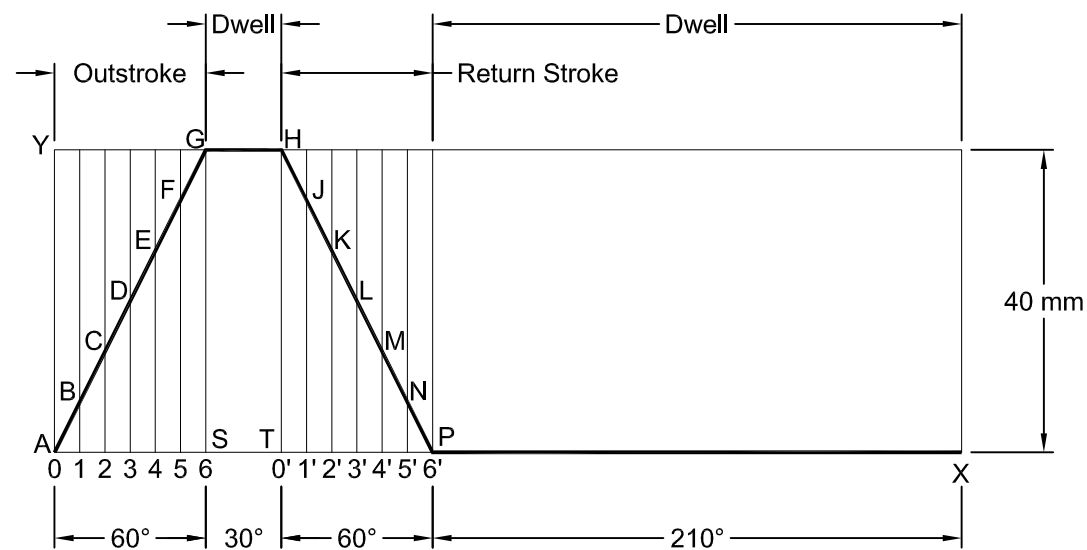

Space or Displacement Diagram

Scale-1:1

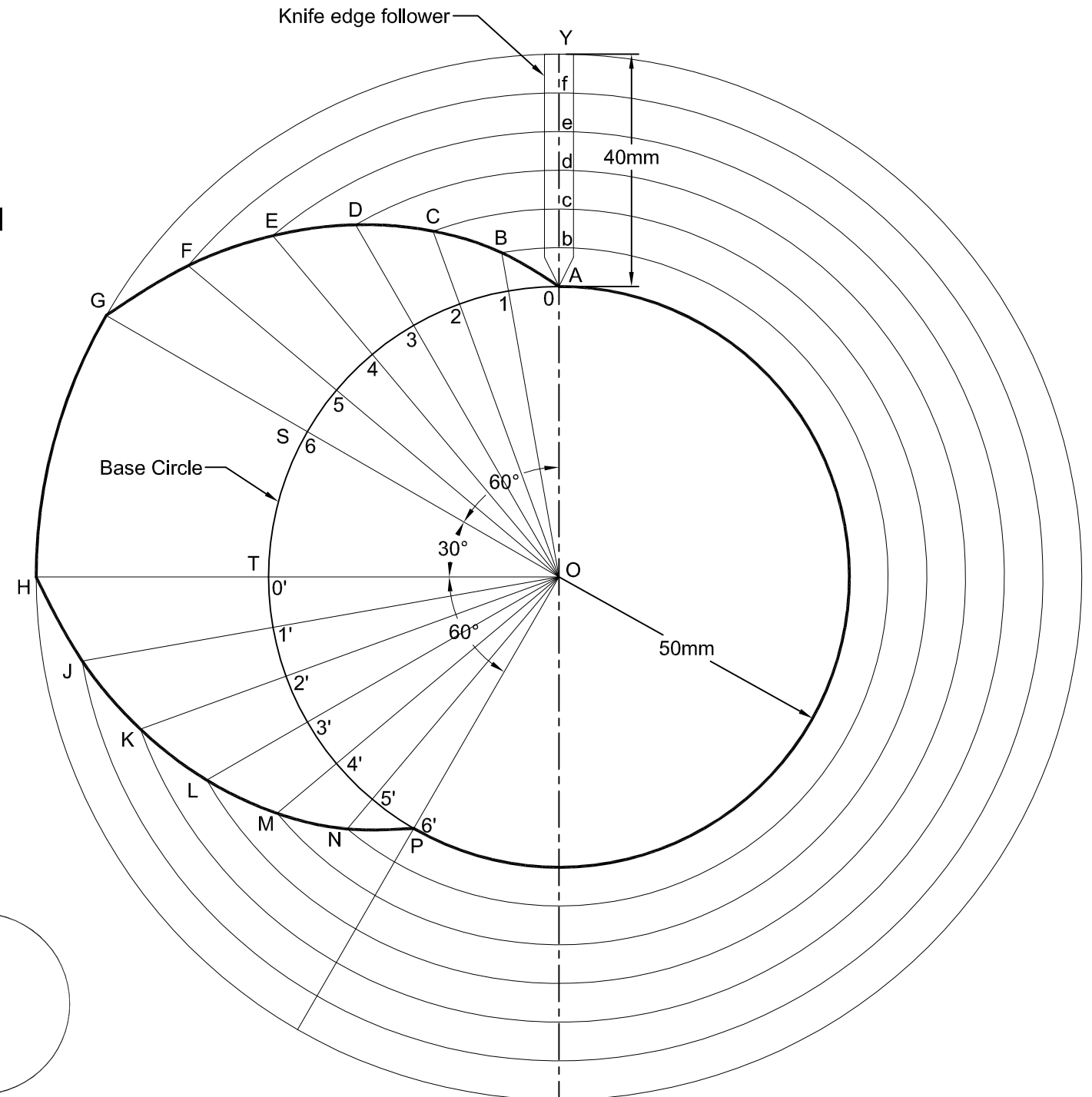

Profile of the cam when the axis of follower passes through the axis of cam shaft

Surface in Contact : Knife Edge

Path of Motion of Follower : Radial

/Motion of the Follower : Uniform Velocity

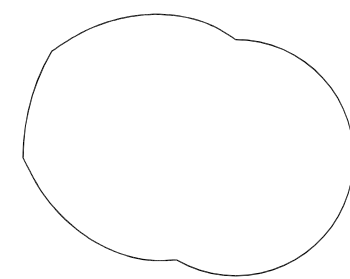

CAM Profile

A cam is to give the following motion to a KNIFE-EDGED FOLLOWER :

1. Outstroke during 60° of cam rotation ; 2. Dwell for the next 30° of cam rotation ; 3. Return stroke during next 60° of cam rotation, and 4. Dwell for the remaining 210° of cam rotation.

The stroke of the follower is 40 mm and the minimum radius of the cam is 50 mm. The follower moves with UNIFORM VELOCITY during both the outstroke and return strokes. Draw the profile of the cam when

- (a) the axis of the follower passes through the axis of the cam shaft, and
- (b) the axis of the follower is offset by 20 mm from the axis of the cam shaft.

Given:

Outstroke Angle = 60° (20mm)	Assume
Dwell (Outstroke) Angle = 30° (10mm)	$30^\circ = 10\text{mm}$
Return Stroke angle = 60° (20mm)	$360^\circ = 120\text{mm}$
Dwell (Return Stroke) Angle = 210° (70mm)	
Stroke = 40mm	
Radius of CAM = 50mm	
Offset = 20mm	

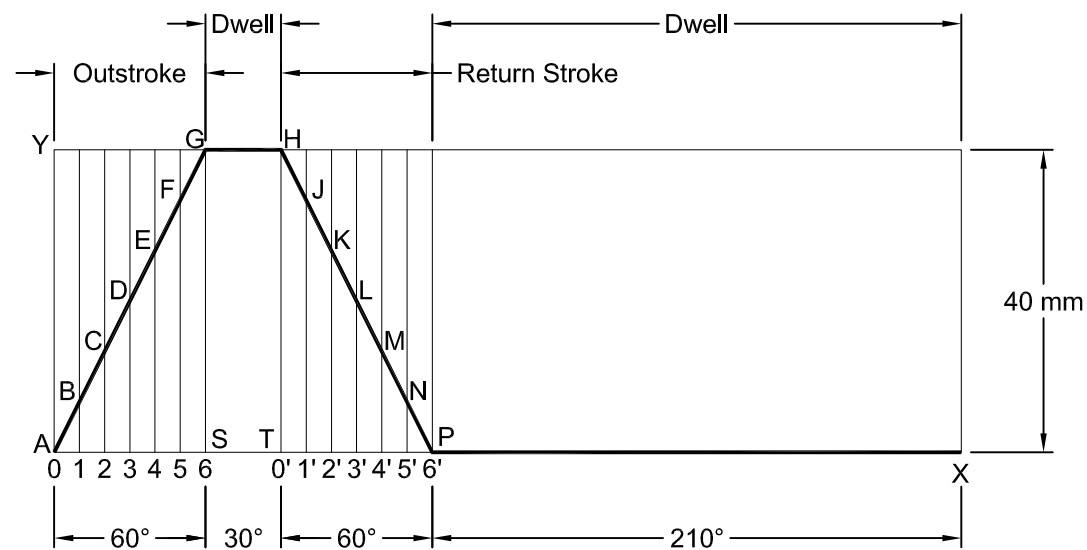

Space or Displacement Diagram

Scale-1:1

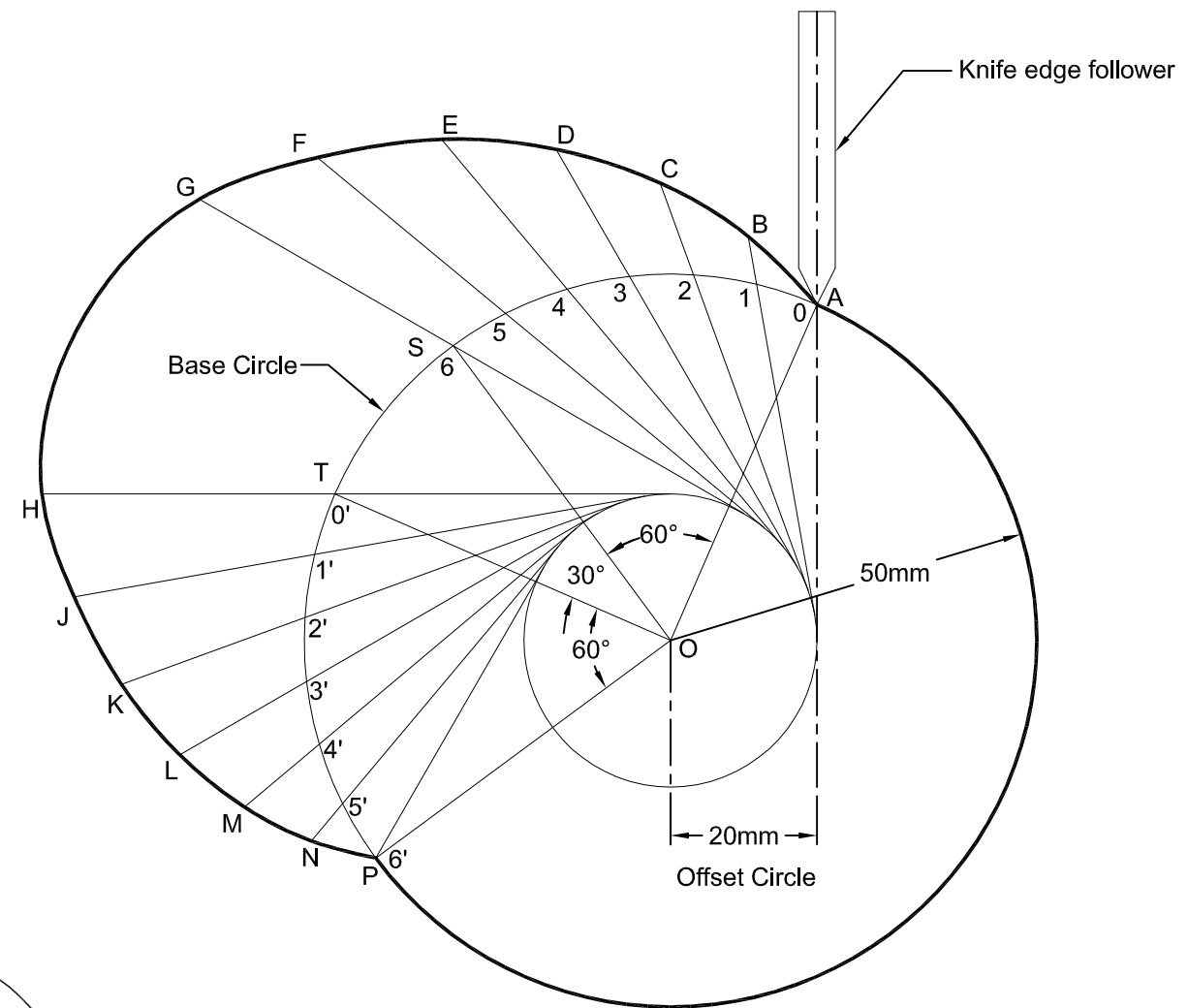

Profile of the cam when the axis of the follower is offset by 20 mm from the axis of the cam shaft

Surface in Contact : Knife Edge

Path of Motion of Follower : Offset

/Motion of the Follower : Uniform Velocity

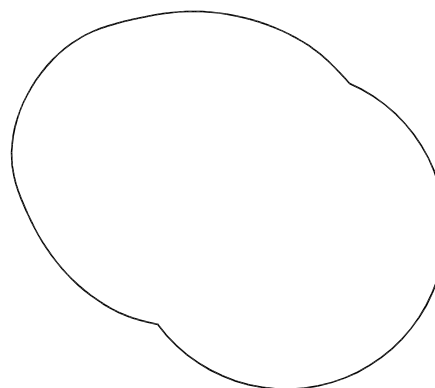

CAM Profile

A cam is to be designed for a KNIFE EDGE FOLLOWER with the following data :

1. Cam lift = 40 mm during 90° of cam rotation with simple harmonic motion. 2. Dwell for the next 30°.
 3. During the next 60° of cam rotation, the follower returns to its original position with SIMPLE HARMONIC MOTION. 4. Dwell during the remaining 180°.
- Draw the profile of the cam when

(a) the line of stroke of the follower passes through the axis of the cam shaft, and

(b) the line of stroke is offset 20 mm from the axis of the cam shaft. The radius of the base circle of the cam is 40 mm. Determine the maximum velocity and acceleration of the follower during its ascent and descent, if the cam rotates at 240 r.p.m.

Given:

- Outstroke Angle = 90° (30mm)
- Dwell (Outstroke) Angle = 30° (10mm)
- Return Stroke angle = 60° (20mm)
- Dwell (Return Stroke) Angle = 180° (60mm)
- Stroke = 40mm
- Radius of CAM = 40mm
- Offset = 20mm
- CAM Speed = 240 rpm

Assume

- 30° = 10mm
- 360° = 120mm

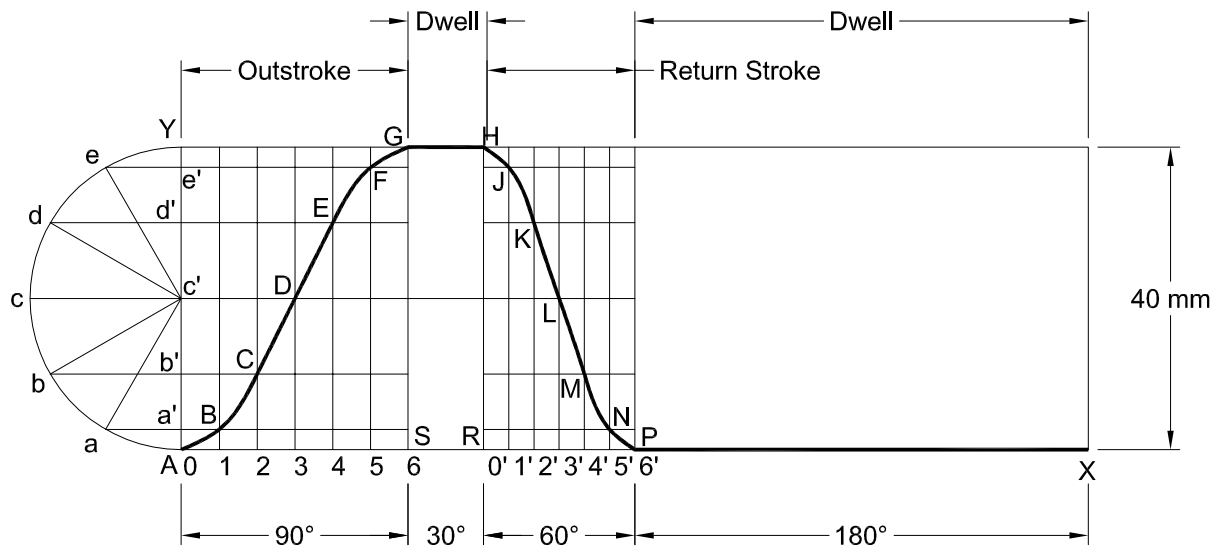

Space or Displacement Diagram

Scale-1:1

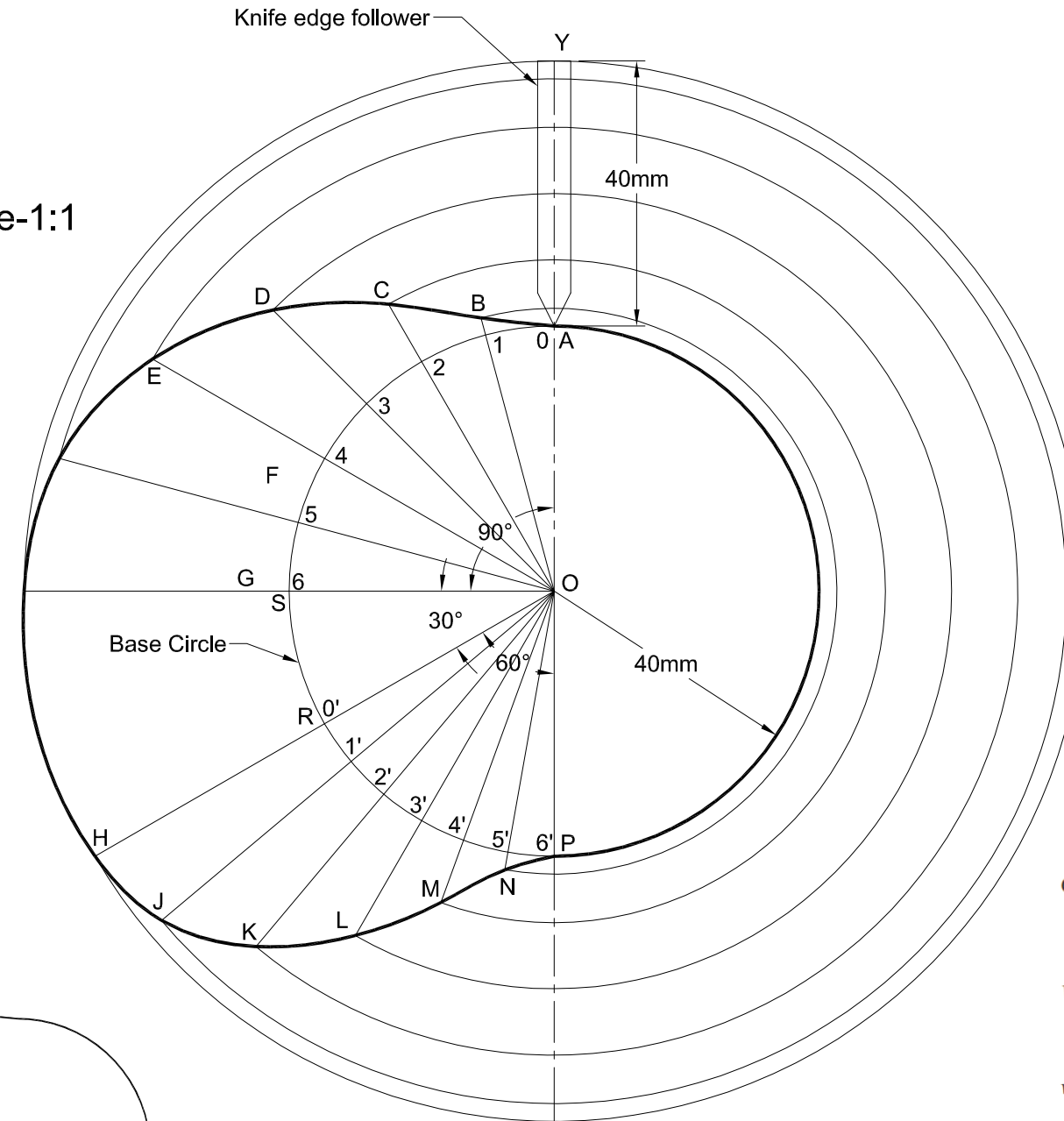

Profile of the cam when the line of stroke of the follower passes through the axis of the cam shaft

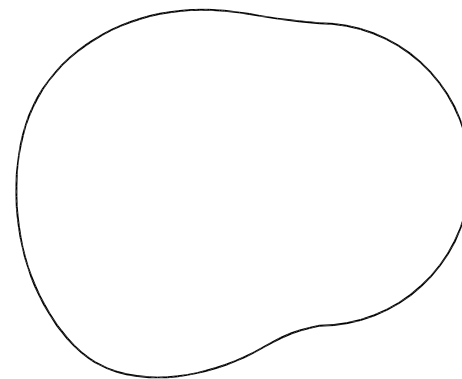

CAM Profile

Surface in Contact : Knife Edge

Path of Motion of Follower : Radial

Motion of the Follower : Simple Harmonic

$$\omega = \frac{2\pi N}{60} = \frac{2\pi \times 240}{60} = 25.14 \text{ rad/s}$$

$$v_O = \frac{\pi \omega S}{2\theta_O} = \frac{\pi \times 25.14 \times 0.04}{2 \times 1.571} = 1 \text{ m/s}$$

$$v_R = \frac{\pi \omega S}{2\theta_R} = \frac{\pi \times 25.14 \times 0.04}{2 \times 1.047} = 1.511 \text{ m/s}$$

$$a_O = \frac{\pi^2 \omega^2 S}{2(\theta_O)^2} = \frac{\pi^2 (25.14)^2 \times 0.04}{2(1.571)^2} = 50.6 \text{ m/s}^2$$

$$a_R = \frac{\pi^2 \omega^2 S}{2(\theta_R)^2} = \frac{\pi^2 (25.14)^2 \times 0.04}{2(1.047)^2} = 113.8 \text{ m/s}^2$$

A cam is to be designed for a KNIFE EDGE FOLLOWER with the following data :

1. Cam lift = 40 mm during 90° of cam rotation with simple harmonic motion.
 2. Dwell for the next 30° .
 3. During the next 60° of cam rotation, the follower returns to its original position with SIMPLE HARMONIC MOTION.
 4. Dwell during the remaining 180° .
- Draw the profile of the cam when

- (a) the line of stroke of the follower passes through the axis of the cam shaft, and
- (b) the line of stroke is offset 20 mm from the axis of the cam shaft. The radius of the base circle of the cam is 40 mm. Determine the maximum velocity and acceleration of the follower during its ascent and descent, if the cam rotates at 240 r.p.m.

Given:

Outstroke Angle = 90° (30mm)
 Dwell (Outstroke) Angle = 30° (10mm)
 Return Stroke angle = 60° (20mm)
 Dwell (Return Stroke) Angle = 180° (60mm)
 Stroke = 40mm
 Radius of CAM = 40mm
 Offset = 20mm
 CAM Speed = 240 rpm

Assume
 $30^\circ = 10\text{mm}$
 $360^\circ = 120\text{mm}$

Scale-1:1

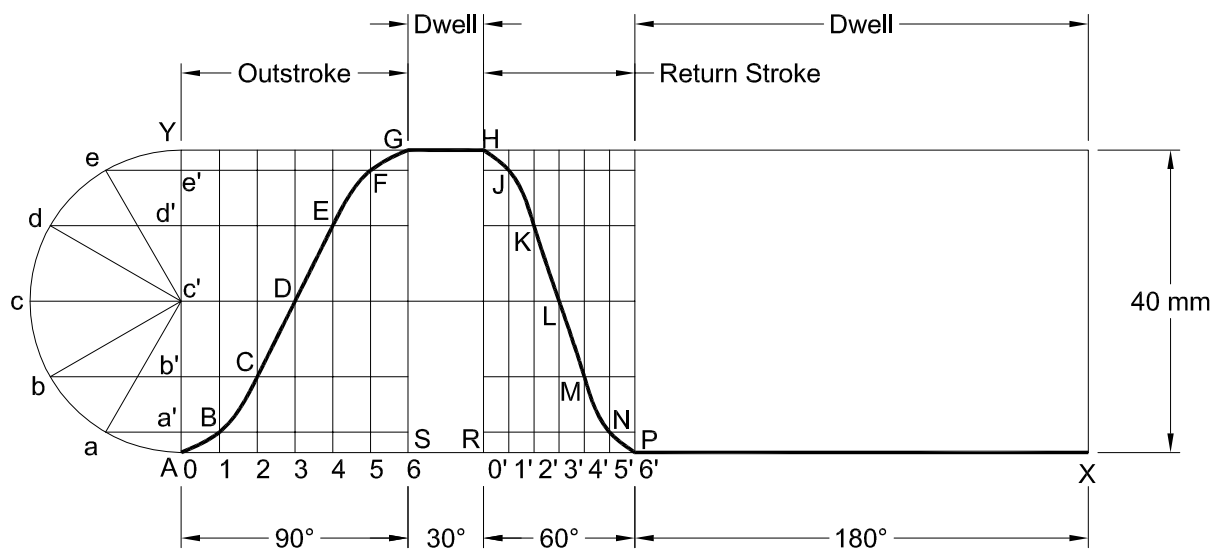

Space or Displacement Diagram

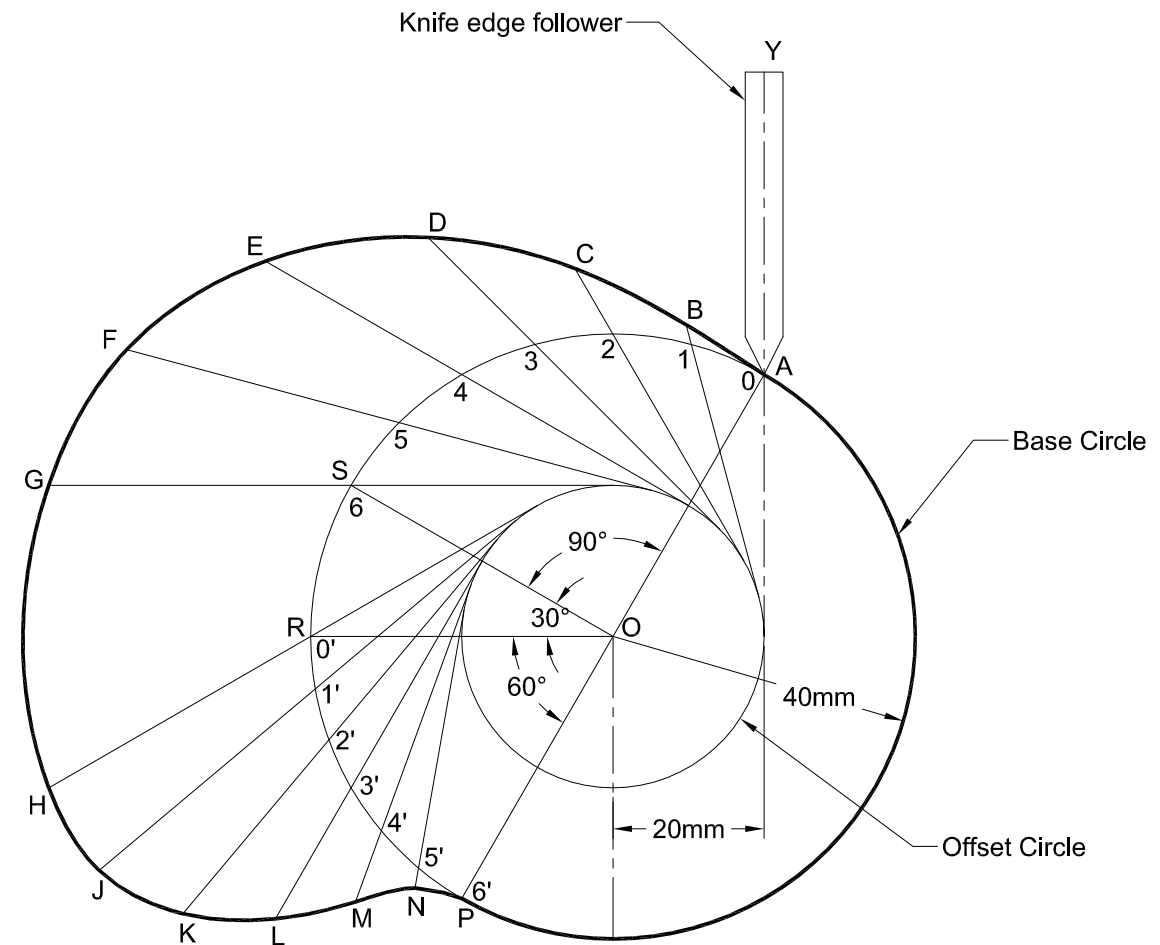

Profile of the cam when the line of stroke of the follower is offset 20 mm from the axis of the cam shaft

Surface in Contact : Knife Edge

Path of Motion of Follower : Offset

Motion of the Follower : Simple Harmonic

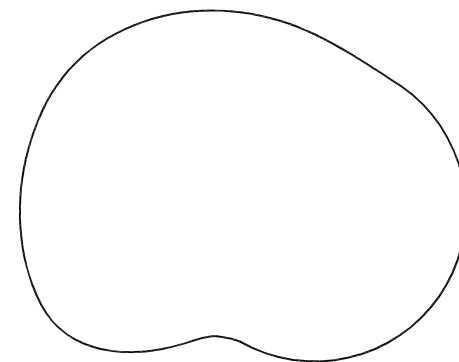

CAM Profile

A cam rotating clockwise at a uniform speed of 1000 r.p.m. is required to give a ROLLER FOLLOWER the motion defined below :

1. Follower to move outwards through 50 mm during 120° of cam rotation,
2. Follower to dwell for next 60° of cam rotation,
3. Follower to return to its starting position during next 90° of cam rotation,
4. Follower to dwell for the rest of the cam rotation.

The minimum radius of the cam is 50 mm and the diameter of roller is 10 mm. The line of stroke of the follower is off-set by 20 mm from the axis of the cam shaft. If the displacement of the follower takes place with UNIFORM AND EQUAL ACCELERATION AND RETARDATION on both the outward and return strokes, draw profile of the cam and find the maximum velocity and acceleration during out stroke and return stroke.

Given:

- | | |
|--|--------------|
| Outstroke Angle = 120° (40mm) | Assume |
| Dwell (Outstroke) Angle = 60° (20mm) | 30° = 10mm |
| Return Stroke angle = 90° (30mm) | 360° = 120mm |
| Dwell (Return Stroke) Angle = 90° (30mm) | |
| Stroke = 50mm | |
| Radius of CAM = 50mm | |
| Offset = 20mm | |
| Roller Dia = 10mm | |
| Speed = 1000 rpm | |

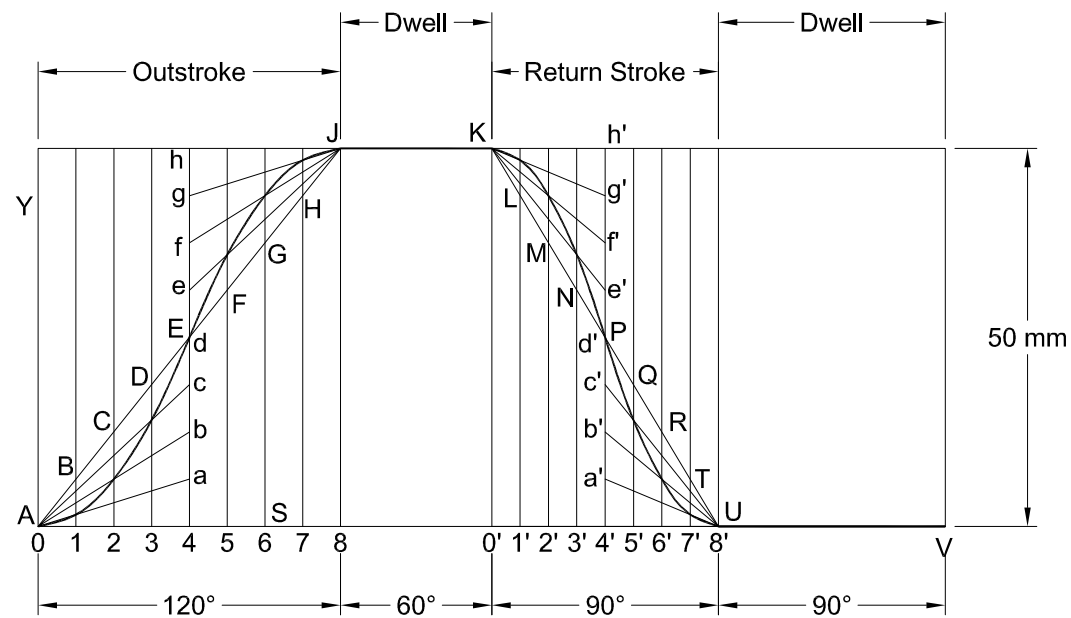

Space or Displacement Diagram

Surface in Contact : Roller

Path of Motion of Follower : Offset

Motion of the Follower : Uniform Acceleration & Retardation

$$\omega = \frac{2\pi N}{60} = \frac{2\pi \times 1000}{60} = 104.7 \text{ rad/s.}$$

$$a_O = \frac{4\omega^2 \cdot S}{(\theta_O)^2} = \frac{4(104.7)^2 \cdot 0.05}{(2.1)^2} = 497.2 \text{ m/s}^2$$

$$v_O = \frac{2\omega \cdot S}{\theta_O} = \frac{2 \times 104.7 \times 0.05}{2.1} = 5 \text{ m/s}$$

$$a_R = \frac{4\omega^2 \cdot S}{(\theta_R)^2} = \frac{4(104.7)^2 \cdot 0.05}{(1.571)^2} = 888 \text{ m/s}^2$$

$$v_R = \frac{2\omega \cdot S}{\theta_R} = \frac{2 \times 104.7 \times 0.05}{1.571} = 6.66 \text{ m/s}$$

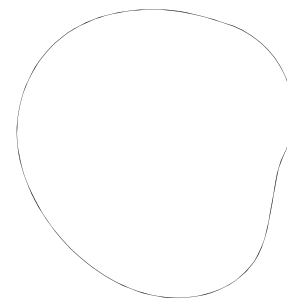

CAM Profile

Scale-1:1

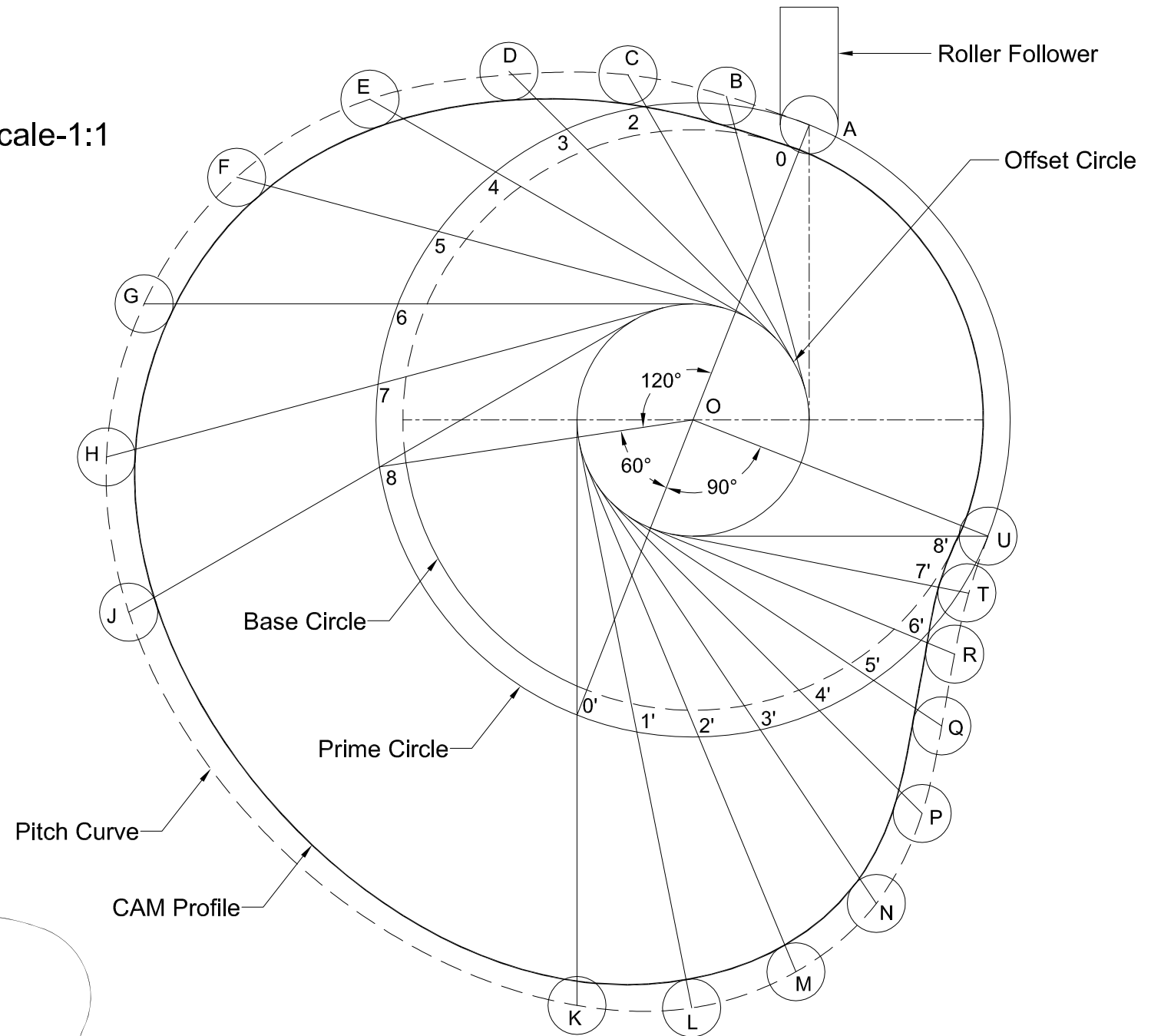

Draw the profile of the cam when the ROLLER FOLLOWER moves with CYCLOIDAL MOTION during out stroke and return stroke, as given below :

1. Out stroke with maximum displacement of 31.4 mm during 180° of cam rotation,
2. Return stroke for the next 150° of cam rotation,
3. Dwell for the remaining 30° of cam rotation.

The minimum radius of the cam is 15 mm and the roller diameter of the follower is 10 mm. The axis of the roller follower is offset by 10 mm towards right from the axis of cam shaft.

Given:

Outstroke Angle = 180° (60mm)
 Return Stroke angle = 150° (50mm)
 Dwell Angle = 30° (10mm)
 Stroke = 31.4mm
 Radius of CAM = 15mm
 Offset = 10mm
 Roller Dia = 10mm

Assume
 30° = 10mm
 360° = 120mm

$$r = \frac{\text{Stroke}}{2\pi} = \frac{31.4}{2\pi} = 5 \text{ mm}$$

Generating Circle

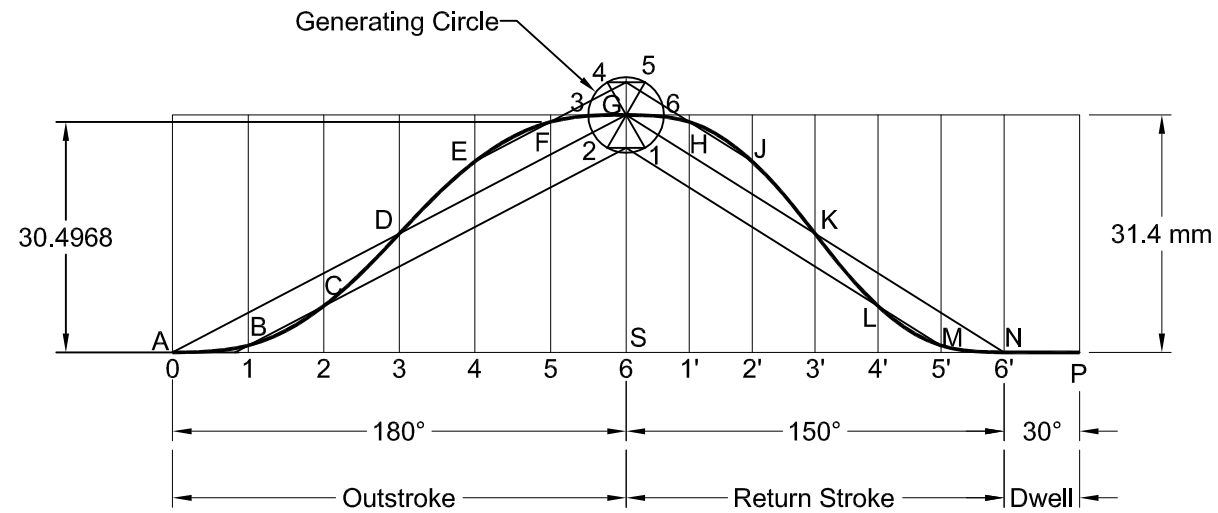

Space or Displacement Diagram

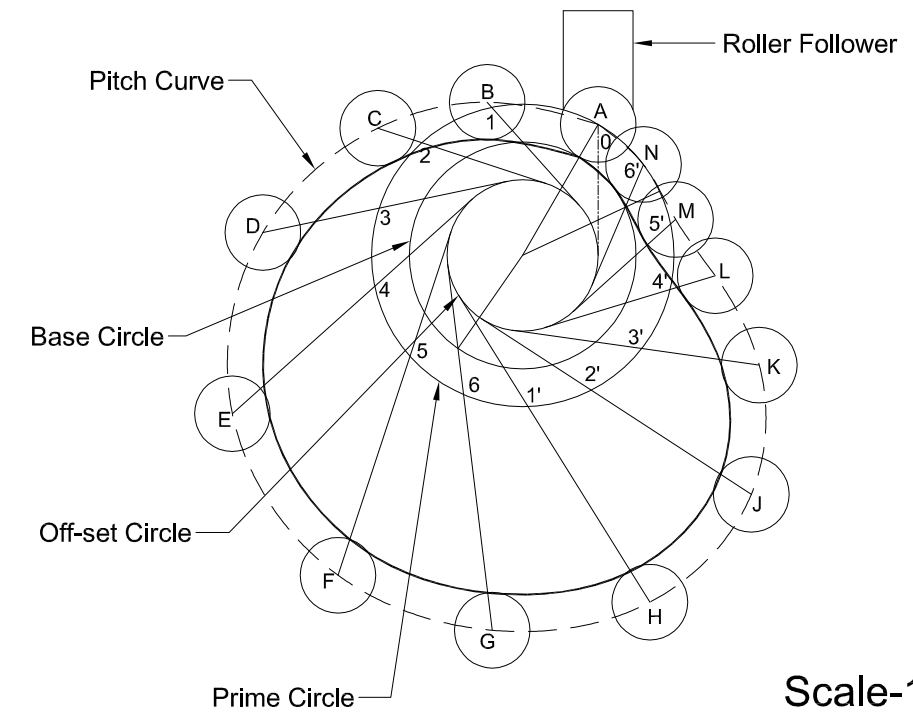

Scale-1:1

Surface in Contact : Roller

Path of Motion of Follower : Offset

Motion of the Follower : Cycloidal

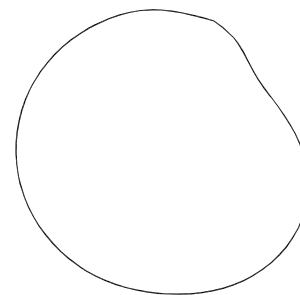

CAM Profile