

Arc welding methods

1. Metal arc welding

It is a process of joining two metal pieces by melting the edges by an electric arc. The electric arc is produced between two conductors. The electrode is one conductor and the work piece is another conductor. The electrode and the work piece are brought nearer with small air gap. (3mm app.)

When current is passed an electric arc is produced between the electrode and the work piece. The work piece and the electrode are melted by the arc. Both molten piece of metal become one. Temperature of arc is about 4000°C Electrodes used in arc welding are coated with a flux. This flux produces a gaseous shield around the molten metal. It prevents the reaction of the molten metal with oxygen and nitrogen in the atmosphere. The flux removes the impurities from the molten metal and form a slag. This slag gets deposited over the weld metal. This protects the weld seam from rapid cooling. Fig.1 shows arc welding process.

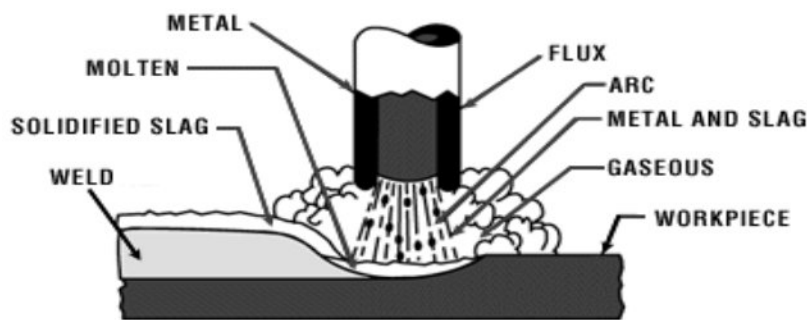

STICK WELDING PROCESS

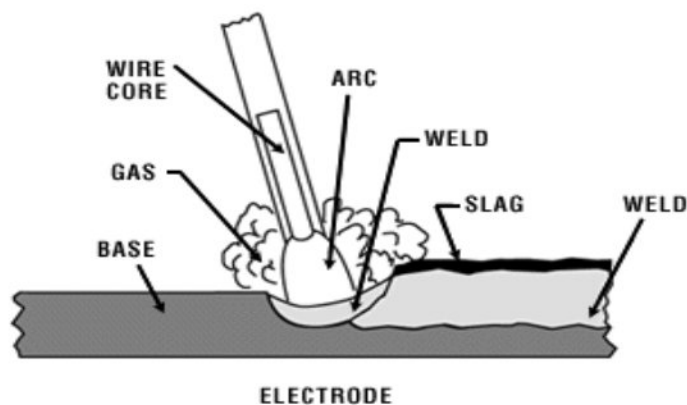

Equipments:(Refer Fig 2)

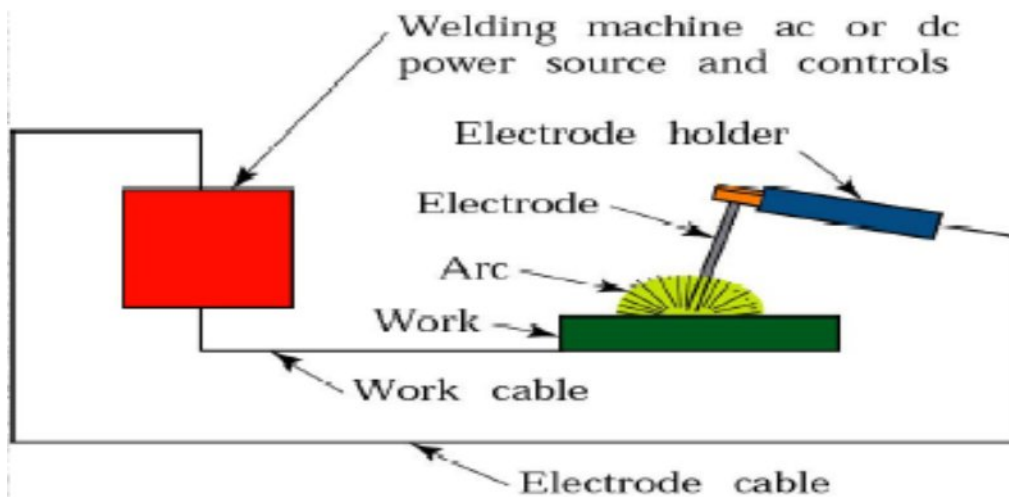

- A welding generator (D.C.) or Transformer (A.C.)
- Two cables- one for work and one for electrode
- Electrode holder
- Electrode
- Protective shield
- Gloves
- Wire brush
- Chipping hammer
- Goggles

Advantages

- Most efficient way to join metals
- Lowest-cost joining method
- Affords lighter weight through better utilization of materials
- Joins all commercial metals
- Provides design flexibility

Limitations

1. Manually applied, therefore high labor cost.
2. Need high energy causing danger
3. Not convenient for disassembly.
4. Defects are hard to detect at joints.

Comparison of A.C. and D.C. arc welding

	Alternating Current (from Transformer)	Direct Current (from Generator)
1	More efficiency	Less efficiency
2	Power consumption less	Power consumption more
3	Cost of equipment is less	Cost of equipment is more
4	Higher voltage – hence not safe	Low voltage – safer operation
5	Not suitable for welding non ferrous metals	suitable for both ferrous non ferrous metals
6	Not preferred for welding thin sections	preferred for welding thin sections
7	Any terminal can be connected to the work or electrode	Positive terminal connected to the work Negative terminal connected to the electrode

Gas-shielded welding can be divided into the tungsten gas-shielded welding and the metal gas-shielded welding processes. The tungsten gas-shielded welding covers the processes

tungsten plasma arc welding (PAW) –
inert-gas tungsten-arc welding (TIG),

whereby TIG welding is the most widely used fusion welding process for aluminium.

The plasma welding consists only of the plasma-arc welding process which works with a transferred arc.

The metal shielded-gas welding is limited to the metal inert-gas welding process operating with an inert gas as shield, as well as a process combination with plasma welding (plasma metal shielded-gas welding - PMIG).

A further subdivision is possible, depending on the mechanism of metal transfer:

– without short-circuits by pulsed arc (p)
– in short circuit with a short arc (sh)

partly short-circuit-free and in short-circuit by the mixed arc (m)
short-circuiting with a long arc (l),

TIG Welding

- Principle of TIG Welding
- TIG welding equipment
- Watercooled TIG welding torch
- Torch forms for TIG welding
- Shielding gases for welding and cutting
- Flow meters
- Flow meter for torches
- Effect of current and inert gas
- Argon consumption for TIG welding
- Tungsten electrodes for TIG welding
- Influence of current type on weld pool
- Arc burning with alternating current
- Action of alternating current during TIG welding of aluminium
- Function of filter condenser
- TIG welding with pulsating square-wave alternating current
- TIG alternating current welding parameters
- Current loading of tungsten electrode
- Manual and mechanised TIG welding
- Macrostructure of TIG welds

Principle of TIG Welding

During TIG welding, an arc is maintained between a tungsten electrode and the work-piece in an inert atmosphere (Ar, He, or Ar-He mixture). Depending on the weld preparation and the work-piece thickness, it is possible to work with or without a filler. The filler can be introduced manually or half mechanically without current or only half mechanically under current

Principle of TIG Welding

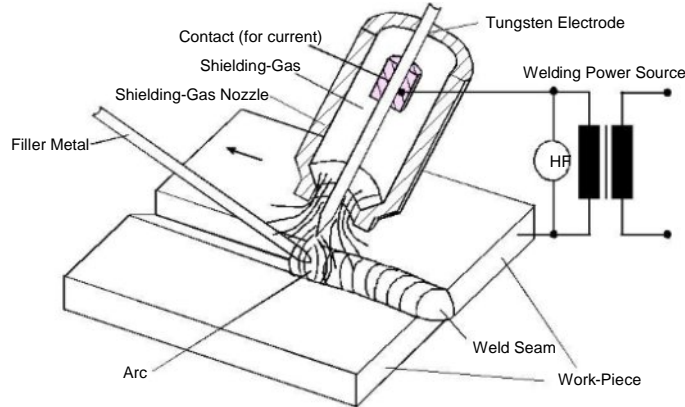

The process itself can be manual, partly mechanised, fully mechanised or automatic. The welding power source delivers direct or alternating current (partly with modulated or pulsed current).

A major difference between the welding of steel and the TIG welding of aluminium is the adhering oxide film on the aluminium surface which influences the welding behaviour and has to be concerned.

This oxide film has to be removed in order to prevent oxides from being entrapped in the weld. The oxide film can be removed by varying the current type or polarity or also through the use of suitable inert gases.

TIG Welding Equipment

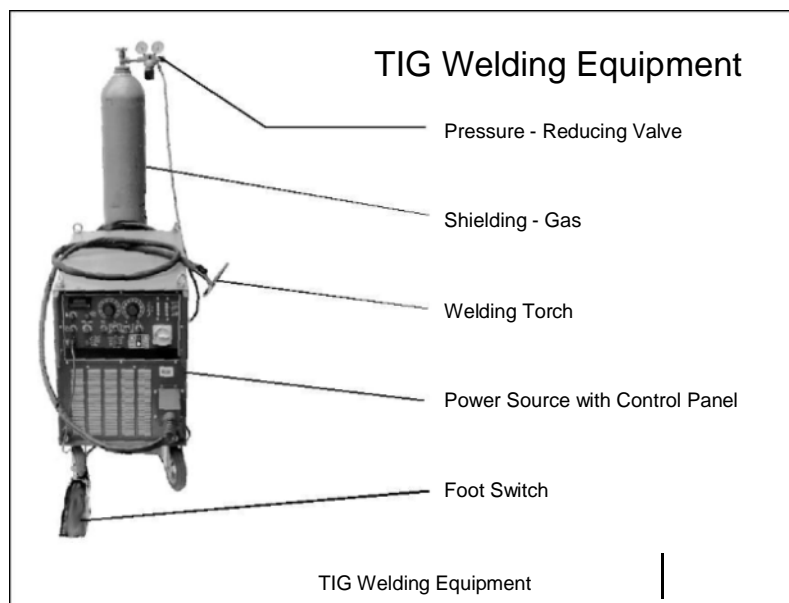

TIG welding equipment consists of the following components:

- Source of welding current (including welding controls, filtering condensers and pulse modulation)
- Torch unit with hose packet
- Gas cylinders with pressure-reducing valve and flow meter

Modern welding power sources can deliver both direct and alternating current.

The power sources have falling characteristic curves. The current can be varied in steps or continuously. The voltage required depends on the distance between electrode and work-piece and determines the operating point on the characteristic line. In modern power sources designed with transistors, the currents and times can be controlled continuously or can be regulated using control programmes.

Watercooled TIG Welding Torch

Depending on the magnitude of thermal stressing, the torches can be air or watercooled (for > 100 A). The watercooling cools both torch and current cable. A flow meter registers any water shortage, switching off the current in this case and thus preventing torch overheating.

In the region of the gas nozzle and the arc burning location, the cooling action is provided by the inert gas. The torch should be airtight since humidity has a negative influence on the welding result (hydrogen absorption). The gas nozzle is made of metal or ceramics and insulated from the electricity conducting parts. The tungsten electrode has a protrusion length of 2 to 4 mm. A torch cap prevents any inadvertent contact with the electrode (**Figure 4201.02.03**).

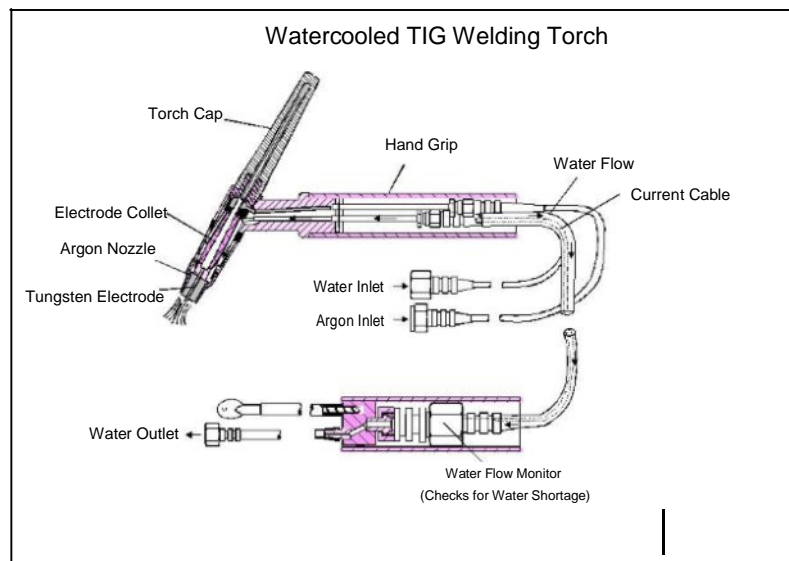

Torch Forms for TIG Welding

Torches of different configurations are necessary to allow for the different accessibilities of the weld seams (work-piece form, welding position). Welding at locations which are difficult to access can be made easier by using the short or elongated torch forms.

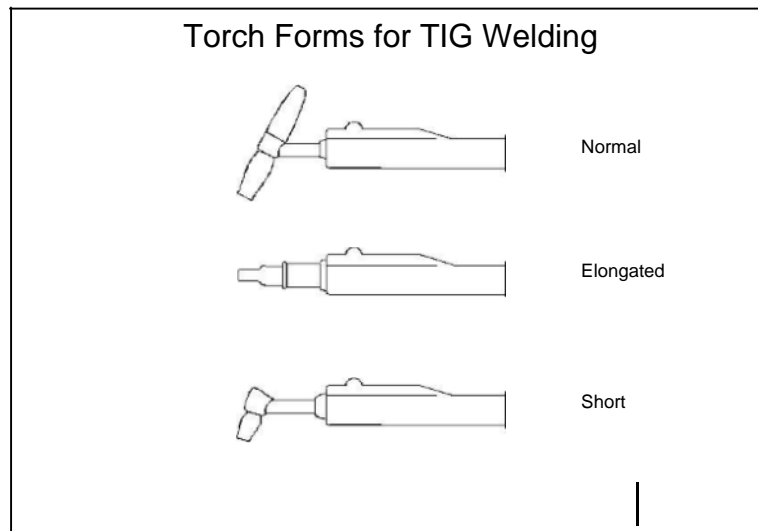

The torch design and size also depend on the type of cooling (air or water cooled)

Shielding Gases for Welding and Cutting

The type of shielding gas used has a major influence on the weld quality. Only inert gases and their mixtures are utilised for welding aluminium, as opposed to the welding of steels (**Figure 4201.02.05**). The required purity of the gases must be guaranteed. It is most important that the limiting value for humidity is not exceeded. The gases are either delivered in compressed form in cylinders or obtained by a vaporisation process (liquefied gas) through pipe lines.

Shielding Gases for Welding and Cutting

Designation		Components in vol. %						Process	Remarks		
Group	Nr.	oxidising		inert		reducing	inactiv				
		CO ₂	O ₂	Ar	He	H ₂	N ₂				
R	1			rest (1-2)		1 ... 15		TIG, PAW, root protection, plasma arc cutting	reducing		
	2			bal. (1-2)		15 ... 35					
I	1			100						TIG, MIG, PAW root protection	inert
	2			rest (1)		100					
	3			rest (1)		20 ... 80					
M1	1	> 0 ...	5	rest (1-2)		> 0 ... 5		MAG	weak oxidising		
	2	> 0 ...	5	rest (1-2)							
	3		> 0 ...	3	rest (1-2)						
	4	> 0 ...	5	> 0 ...	3	rest (1-2)					
M2	1	> 5 ...	25	rest (1-2)							
	2		> 3 ...	10	rest (1-2)						
	3	> 5 ...	25	> 0 ...	8	rest (1-2)					
M3	1	> 25 ..	50	rest (1-2)							
	2		> 10 ...	15	rest (1-2)						
	3	> 5 ...	50	> 8 ...	15	rest (1-2)					
C	1	100						root protection	strongly oxidising		
	2	rest	> 0 ...	30							
F	1					0 ... 30	rest	root protection	reducing		

Shielding Gases for Welding and Cutting

Flow Meters

The pressure of the gas contained in cylinders is reduced by pressure-reducing valves (Manometers for indicating cylinder pressure).

The amount of gas flowing in l/min is controlled via a regulating valve and indicated by the flow meter. In order to prevent any errors, the pressure-reducing valves have a colour code corresponding to the gas type (black for inert gases).

The type of gas used is also indicated in the manometer (**Figure 4201.02.06**).

Flow Meter for Torches

Flow meters which can be fixed directly to the torch nozzle have proved to be very practical. This shows the amount of gas actually passing through the torch in l/min. A correction factor has to be used for the varying gas densities of the Ar-He mixtures or the pure helium used (He: 0.1785 kg/Nm³, Ar: 1.7844 kg/Nm³) (**Figure 4201.02.07**).

Gas Flow Meters

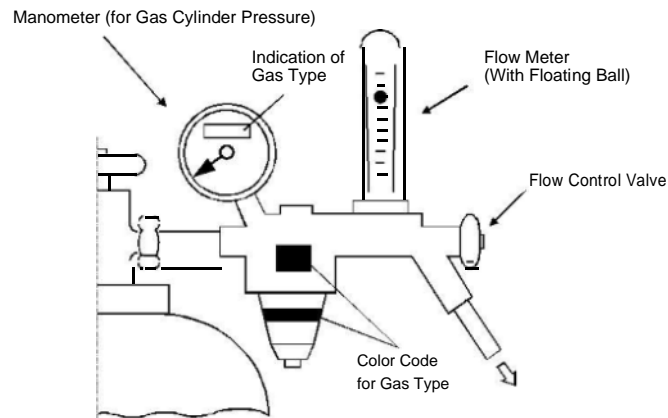

Effect of Current and Inert Gas

Both direct and alternating currents are used for welding aluminium. The weld pool and the weld forms can be regulated by controlling the current type and the polarity. The heat developed is highest when helium is used.

In direct-current, straight -polarity welding (electrode is negative with respect to aluminium), the heating of the electrode is kept to a minimum but the cleaning action on the weld pool is also minimum. Helium is used as the shielding inert gas. The breakdown of the oxide film is a result of the thermal stressing, i.e., melting occurs. Because of its high melting point (ca. 2050 °C), the oxide layer cannot be melted using argon as the shielding gas.

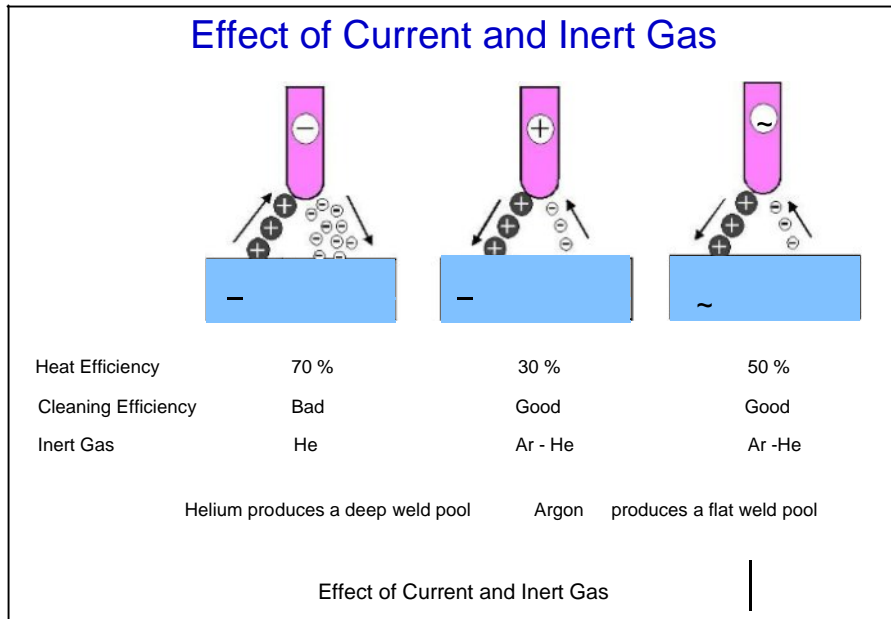

When direct-current reverse-polarity is used (electrode is positive with respect to aluminium), excessive heating of the electrode occurs, so that the electrode life is reduced or, as in some cases, even melting of the electrode end can occur.

The reverse polarity (electrode positive) has a lower energy density so that the weld pool is shallower than in the case of straight polarity (electrode negative). Thus it is only used for welding thin-walled parts with low currents. However, good cooling and large-diameter electrodes are necessary. The alternating-current welding is a compromise solution

Argon Consumption for TIG Welding

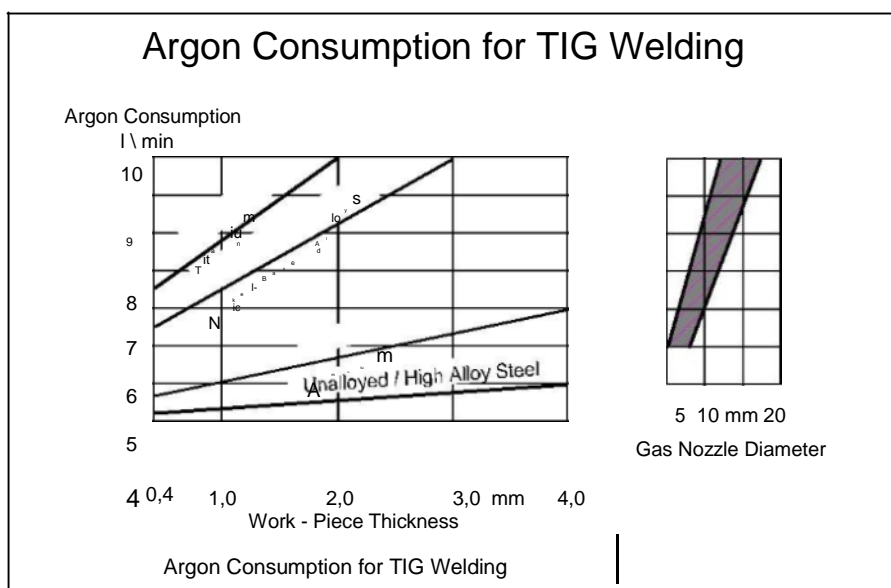

The amount of shielding gas required depends on the material used and its thickness.

The gas consumption for titanium is higher than for steel, since a gas absorption by the former material must be prevented even at lower temperatures.

Thus, trailing nozzles have to be used.

The gas nozzle diameter has to be optimised for the electrode diameter used.

Because of its lower density, the amount of argon required is larger than the helium amount needed

Tungsten Electrodes for TIG Welding

Oxide additions (oxides of thorium, zircon, lanthan and cer) to the tungsten electrode reduce the electron emission energy (pure tungsten 5.36 eV, thorated 2.62 eV).

This improves:

- the arc stability
- electrode life
- current loading capacity
- arc igniting properties.

Tungsten Electrodes for TIG Welding						
Designation	Material No.	Oxide Additions Wt. %	Impurities Wt. %	Tungsten Wt. %	Colour Code	RAL No.
W	2.6005	-	≤ 0.20	99.8	Green	6018
WT 10	2.6022	0.90 - 1.20 ThO ₂	≥ 0.20	Rest	Yellow	1018
WT 20	2.6026	1.80 - 2.20 ThO ₂	≥ 0.20	Rest	Red	2002
WT 30	2.6030	2.80 - 3.20 ThO ₂	≥ 0.20	Rest	Violet	4003
WT 40	2.6036	3.80 - 4.20 ThO ₂	≥ 0.20	Rest	Orange	2003
WZ 4	2.6050	0.30 - 0.50 ZrO ₂	≥ 0.20	Rest	Brown	8001
WZ 8	2.6062	0.70 - 0.90 ZrO ₂	≥ 0.20	Rest	White	9010
WZ 10	2.6010	0.90 - 1.20 LaO₂	≤ 0.20	Rest	Black	9005

Tungsten Electrodes for TIG Welding

Training in Aluminium Application Technologies

Thorated tungsten electrodes are most commonly used. For nuclear reactor construction, zircon oxide additions have proved effective. Lanthated electrodes are used for micro plasma welding and for plasma arc cutting

Influence of Current Type on Weld Pool

The type of current used influences the weld pool created and the weld form as well as the form of the electrode used.

Current loading and life of the electrode are much higher when the electrode is set to a negative polarity, since the emission of electrons from this hot electrode tip requires less energy than in the case of positive electrode polarity, where the electrons have to be emitted from the cold work-piece surface.

The electrons emitted from the negative electrode bombard the work-piece giving up their kinetical energy as heat to produce a narrow and deep weld pool. The electrode tip is thin and narrowly tapered. The high-melting oxide film is not destroyed here, i.e., there is no cleaning action of the weld pool.

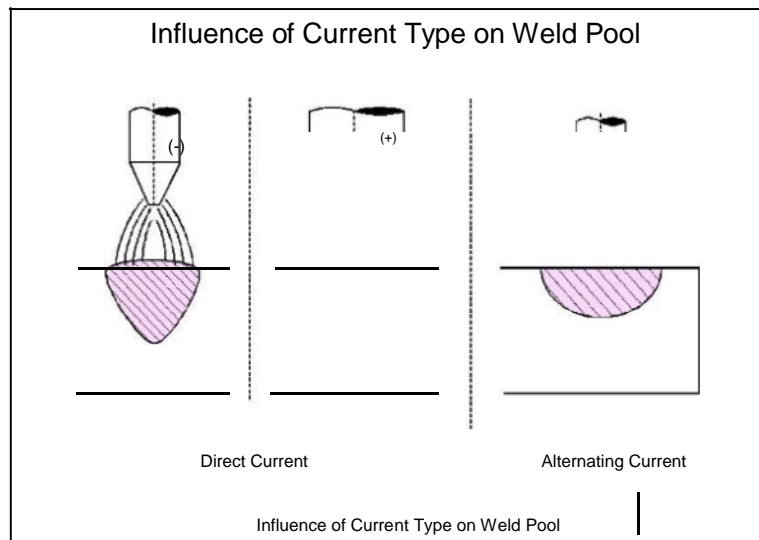

Conditions are reversed when the electrode is made positive with respect to the work-piece. The electrons give up their kinetic energy to the electrode, causing an excessive heating of the electrode. Consequently, large-diameter electrodes with wide-angled tips have to be used. The weld pool is broader and flatter.

Alternating current welding combines the characteristics of the above mentioned two variations

Arc Burning with Alternating Current

In the alternating current welding, both current and voltage pass through a zero-phase, causing a periodic extinction of the arc. High voltage pulses are essential both in the negative as well as in the positive half-cycle to ignite the arc after each zero-phase is crossed (**Figure 4201.02.12**).

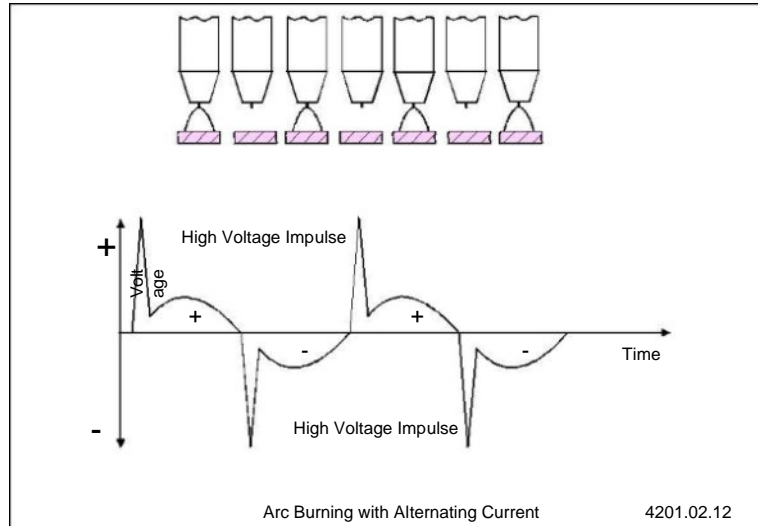

Action of Alternating Current during TIG Welding of Aluminium

The oxide film can be destroyed or broken up thermally under helium gas shielding (direct-current, straight-polarity - electrode negative) or mechanically (alternating current under argon or Ar-He mixture).

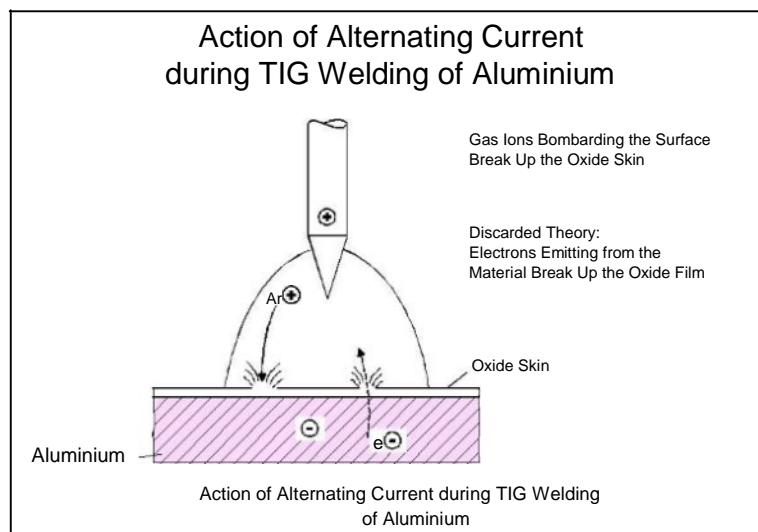

During the positive phase of the alternating current welding, gas ions are accelerated away from the electrode (anode) in the direction of the work-piece.

The bombardment with the relatively heavy ions breaks up the oxide film, thereby cleaning the weld pool (cleaning half-wave). At the same time, an electron stream bombards the electrode. The kinetic energy of the electrons is converted here, causing excessive heating of the electrode

A cooling half-wave in which the electrode has a negative polarity follows the cleaning half-cycle (electrode positive). The electrons emitting from the electrode (cathode) bombard the work-piece causing the temperature to rise, without, however, being able to break up the oxide film. On the other hand, the ions striking the electrode hardly cause any heating of the electrode, so that the previously heated electrode can cool down. The alternating polarity increases the life of the electrode and also has the desired cleaning effect on the weld.

According to current theories, a bombardment with electrons has no cleaning effect. The release energy of electrons from the oxide layer is 50 % less than from pure aluminium. Consequently, the electrons are emitted from the oxide film and not from the metal surface lying under it. Thus, a "tunnelling" or breaking up of the oxide film is not possible.

Function of Filter Condenser

While welding with alternating current, the maximum voltage amplitudes during the positive and negative half-cycle are not the same; one refers to this as the rectifying effect. The differences in the electron emission characteristics of the metal (or oxide) and the electrode cause the alternating current to be unbalanced.

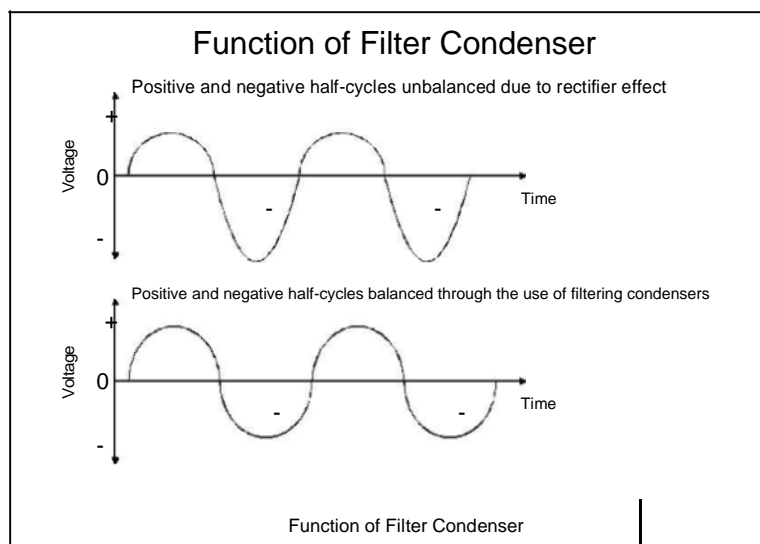

The electron emission of the incandescent tip of the tungsten electrode is very much larger than that of the relatively cold weld pool surface, so that the amplitude of the negative half-cycle is higher. This effect reduces the cleaning action and the stability of the arc.

Filter condensers are used to produce a balanced wave (**Figure 4201.02.14**).

TIG Welding with Pulsating Square-Wave Alternating Current

With modern power sources it is possible to weld with impulse overlay and alternating polarity of the direct current as well as with square-waved alternating current. Thus it is possible to choose the pulse duration and pulse pauses as well as the pulse amplitude independently.

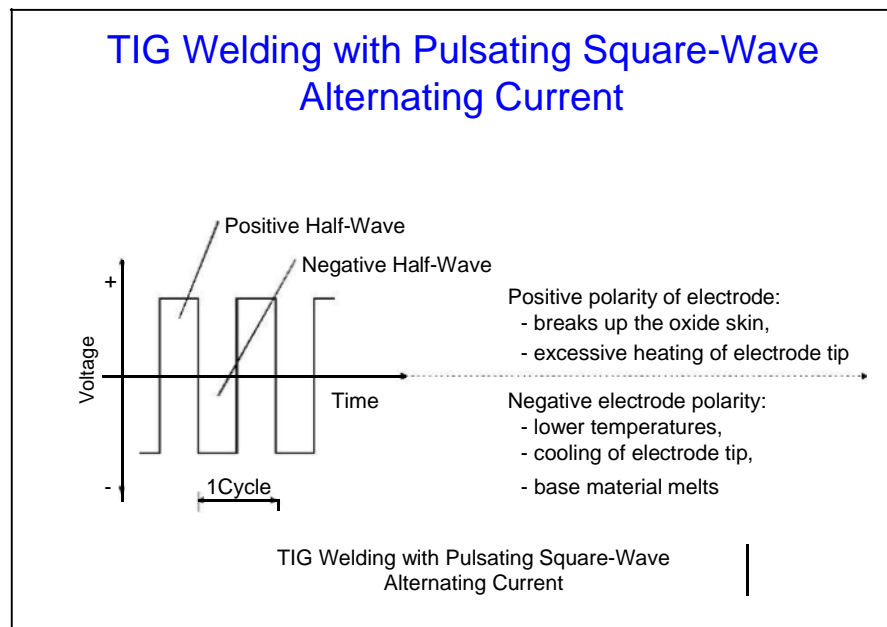

The balanced-wave alternating current (positive and negative half-cycles are symmetrical) can be altered so that the cleaning half-cycle duration is reduced and the cooling-phase half-cycle duration increased. Thus, the positive phase - heavily reduced in duration and amplitude - serves only as the cleaning phase, and the negative phase exclusively as the melting phase. The square-wave form of the alternating current has the added advantage that the steep transition from positive to negative guarantees the ignition of the arc without having to use a high frequency overlaying voltage (**Figure 4201.02.15**).

TIG Alternating Current Welding Parameters

The maximum current strengths used for alternating current welding are around 400 A, the current strength for direct current welding being around 600 A (negative polarity under helium). The guiding values for manual and fully mechanised welding can be obtained from the corresponding tables

The direct current welding with helium is generally fully mechanised. The small arc length (ca.1mm) which must be maintained for this type of welding makes manual welding very difficult.

TIG Alternating Current Welding Parameters

Work Thickness	Alternating Welding Current in A			Tungsten Electrode Diameter	Welding Rate	Welding Rod Diameter	Argon Consumption	No. of Passes
	PA	PF	PE					
mm	PA	PF	PE	mm	cm/min	mm	l/min	
1	50-60	40-60	40-60	1.6	30	2.0	3-5	1
2	80-100	75-95	70-60	1.6-2.4	30	2.0	4-7	1
4	160-190	155-185	150-180	2.4	28	3.0	4-9	1
6	250-290	210-250	200-240	3.2-4.0	25	4.0	6-10	2
8	300-350	240-290	230-280	4.8	20	4.0	8-12	2-3
10	330-380	250-300	250-300	4.8-6.4	15	6.0	10-14	3-4

TIG Alternating Current Welding Parameters

Current Loading of Tungsten Electrode

The current strengths required can be estimated from the form of the tungsten electrode. For direct current welding, the electrode is ground to an angle of ca. 20 to 25°. The arc should surround the tip symmetrically. Too high currents cause the tip to melt. Due to the lower thermal stressing, small-diameter electrodes can be used for direct current welding.

Current Loading of Tungsten Electrode

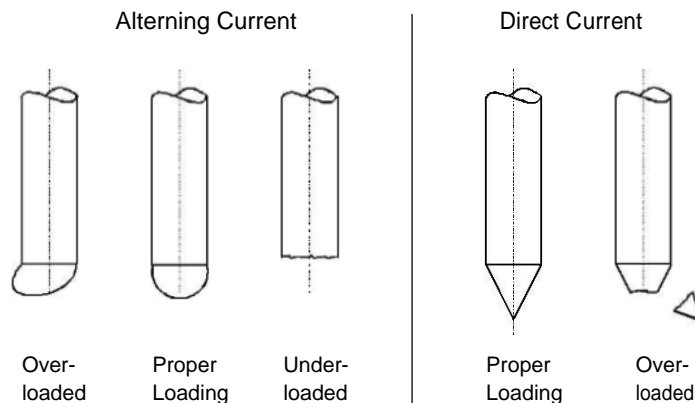

Current Loading of the Tungsten Electrode

During alternating current welding, thicker electrodes are used. When the proper current strength is used, a hemispherical molten bead is formed at the end of the electrode. This bead, however, should not be allowed to grow too large in size. When the current strength is too low, only a local melting occurs

Manual and Mechanised TIG Welding

Depending on the torch manipulation and the filler metal introduction, one refers to

- manual welding (torch and filler metal are manipulated by hand, as in gas welding) or
- fully mechanised welding (torch and filler metal are manipulated mechanically)

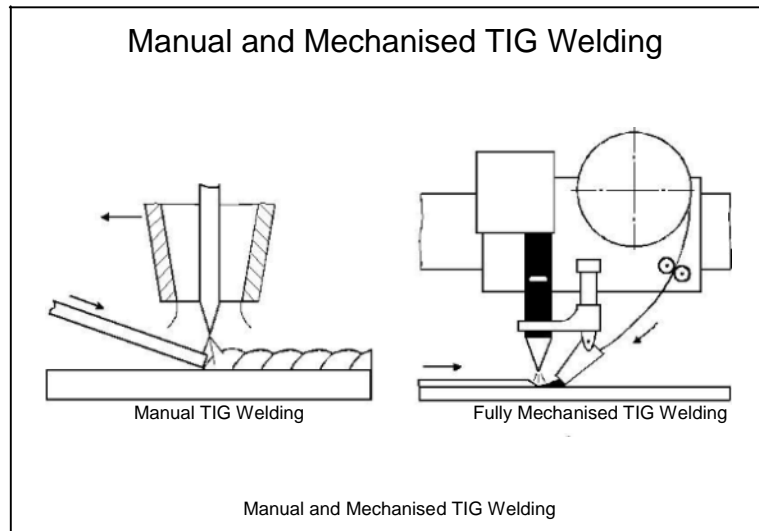

Macrostructure of TIG Welds

Current type and polarity as well as the shielding gas type influence the weld geometry.

The micrograph shows a flat and broad penetration during positive polarity under argon gas shielding. The mixing of helium to argon in the alternating current welding, produces a broader penetration profile

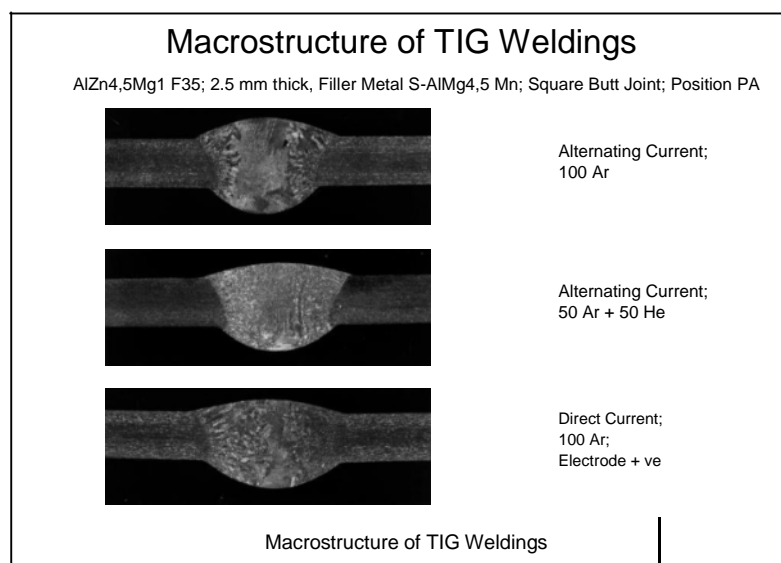

4201.03 Plasma Arc Welding

- Principle of plasma arc welding
- Arc form during TIG and tungsten plasma-arc welding
- Weld Pool Form and Heat Affected Zone
- Varying Arc Stabilities
- Principle of the Keyhole Plasma Arc Welding
- Guide Values for the Positive Polarity Plasma Arc Welding
- Principle of the VPPA Welding
- Guide Values for the VPPA Welding
- Macrostructure of VPPA Welds
- Advantages of Plasma Arc Welding over to TIG Welding
- Process Steps of the Plasma Arc Cutting
- Guide Values for Plasma Arc Cutting
- Characteristics which Determine the Quality of a Plasma Arc Cut

Principle of Plasma Arc Welding

Thermal plasma consists of electrons, ions and neutral particles under high temperature and subject to a disordered violent movement. The molecules are partly dissociated and the atoms ionised. During collision with the work-piece surface, these give their energy up to the work and recombine.

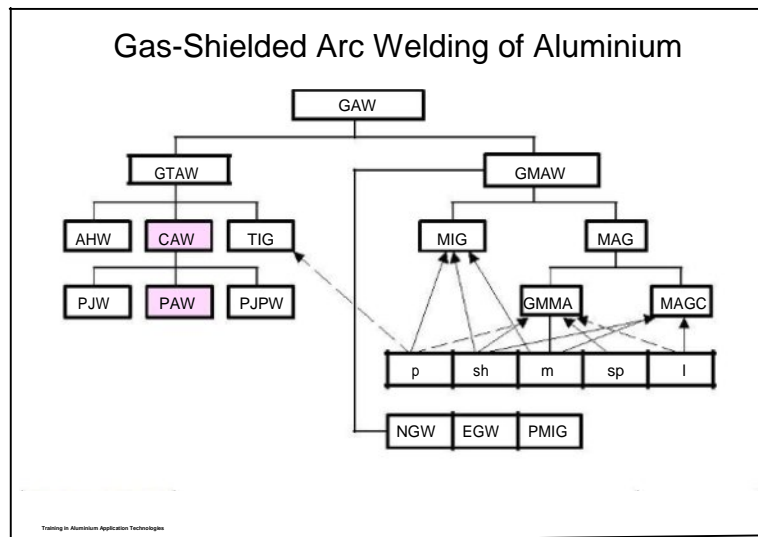

The plasma is concentrated in the inside of the jet, thereby delivering a narrow plasma jet with a very high energy density. The plasma arc is, therefore, constricted and arcs between the tungsten electrode and the work-piece. The shielding gases used here are exclusively inert gases like argon, helium or a mixture of these gases. The tungsten electrode has a negative polarity and the work-piece a positive polarity (straight polarity).

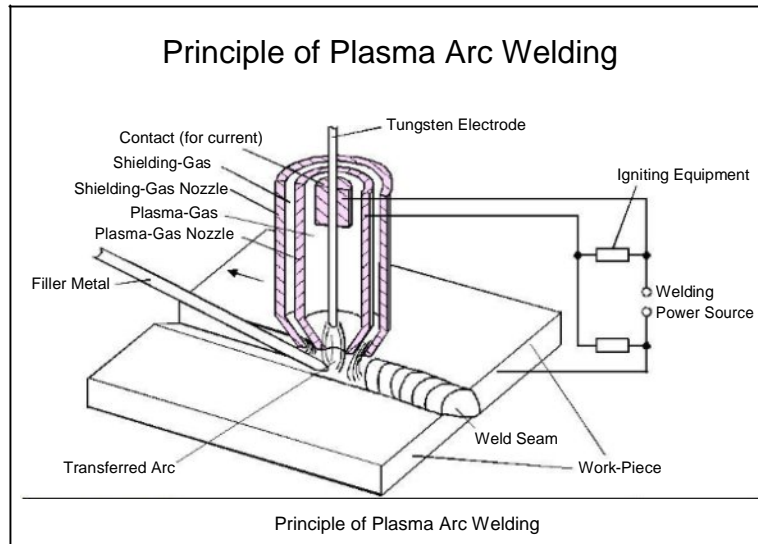

Arc Form during TIG and Tungsten Plasma-Arc Welding

Compared to the TIG arc, the constricted plasma arc has a much lower divergence, i.e., much larger changes in arc length can be tolerated. Thus, for example, a 20 % increase of arc cross-section corresponds to a ten times larger length of the plasma arc than of the TIG arc. This explains the relative insensitivity of the plasma arc to surface unevenness

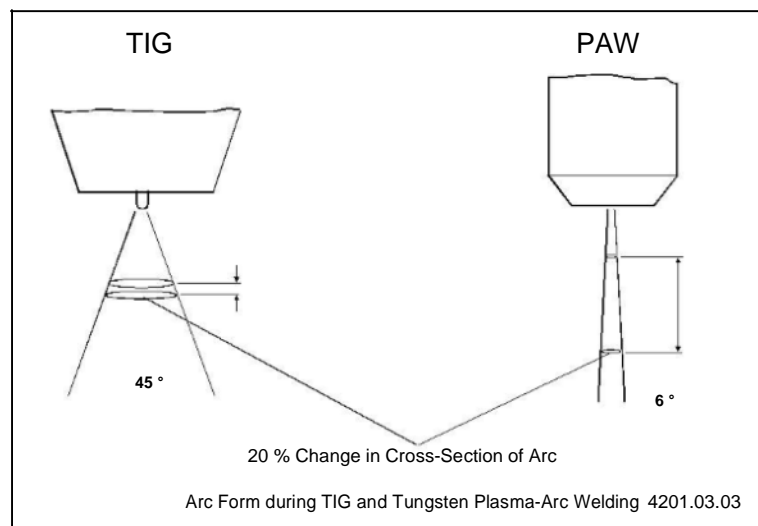

Weld Pool Form and Heat Affected Zone

The ratio of penetration (weld depth) to weld width is twice as large for plasma arc welding as for TIG welding, making it possible to create narrow, deep weld profiles. Consequently, thicker sheets can be welded using square butt joints.

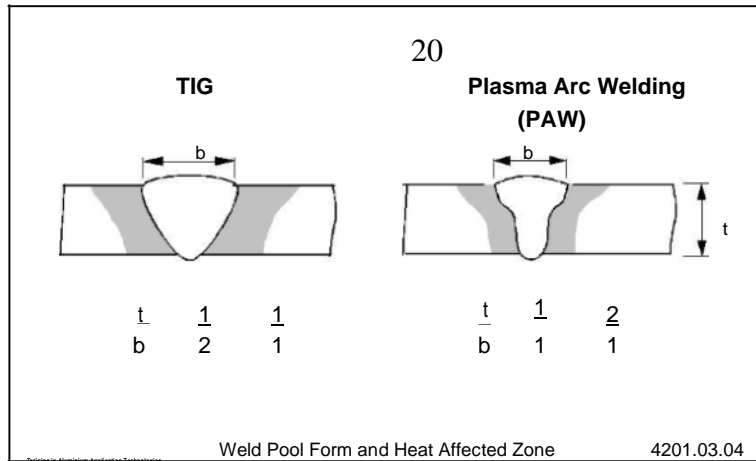

The amount of filler metal and the heat input is much lower, so that distortion is less and heat sensitive materials can be better controlled.

The overhead shows a plasma arc weld with a "wine glass" type of weld penetration

Varying Arc Stabilities

The bundled and strongly constricted plasma stream is stabler than in the TIG process. The plasma arc does not tend to "stick" to edges and the weld pool (**Figure 4201.03.05**).

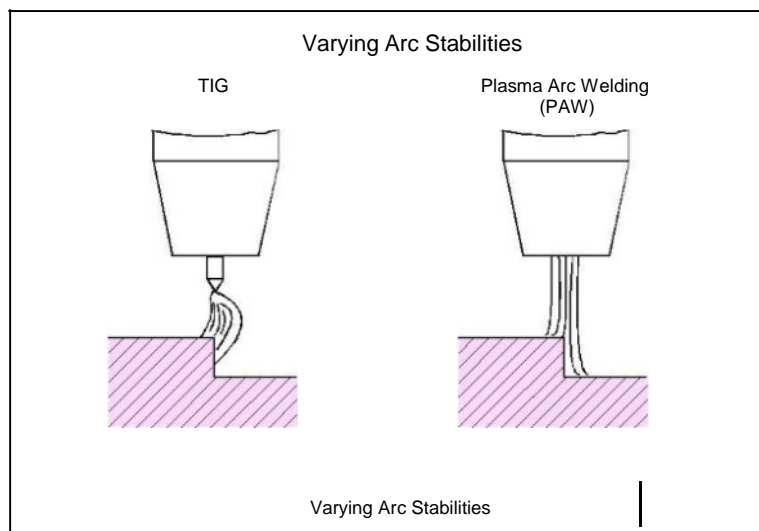

Principle of the Keyhole Plasma Arc Welding

Because of its high energy density, plasma arc welding is suitable for welding thicker cross-sections. One variation is the keyhole plasma arc welding. The plasma arc pierces through the welding parts and pushes the weld pool to the sides. By proper choice of

process parameters, it is possible to form a weld pool which holds itself by its own surface tension. The molten metal behind the keyhole flows together and solidifies again (**Figure 4201.03.06**).

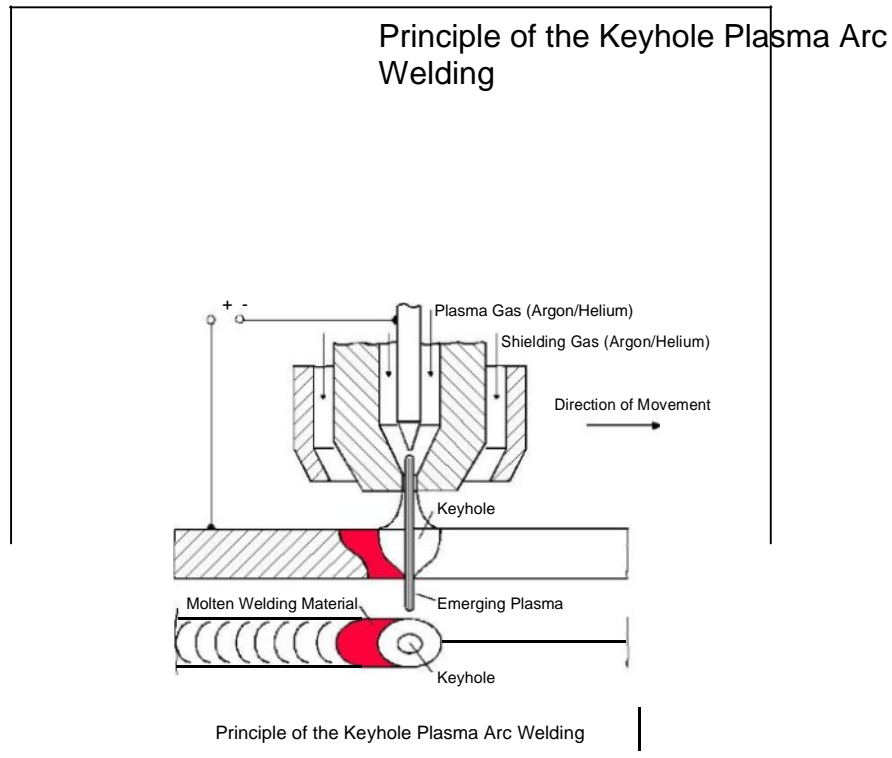

The energy is delivered over the total thickness of the work-pieces and not only to the surface. This leads to in-depth welding at high speeds.

The high viscosity of the weld pool makes it possible to weld parts in a horizontal position which are up to about 5 mm thick. Thicker materials have to be welded in a vertical position with the plasma jet moving upwards. The keyhole plasma arc welding can only be carried out in a mechanised process.

Guide Values for the Positive Polarity Plasma Arc Welding

Because of the excessive heat produced at the positively poled electrode, the current strength should be limited to a maximum of about 170 A. Currents of up to 300 A can be used for water-cooled copper electrodes (**Figure 4201.03.07**).

Principle of the VPPA Welding

The VPPA welding of aluminium (Variable Polarity Plasma Arc) is a variant of plasma arc welding with a square-waved alternating current. The power sources used allow the amplitude and duration of the negative half-cycle and the positive half-cycle to be varied independently (variable polarity).

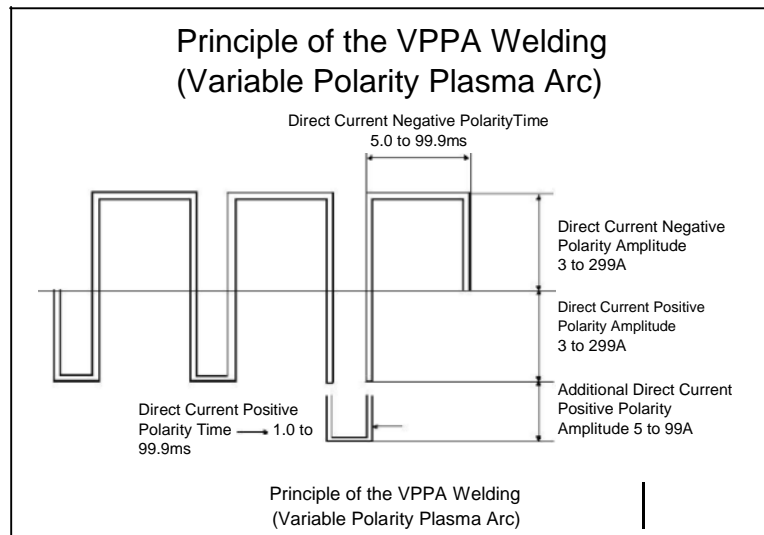

At the same time, the positive half-cycle can be overlaid with a direct current of variable amplitude

Depending on the alloy composition, the filler metal, the wire thickness and the sheet thickness, following parameters can be set:

- wire feed and
- welding rate,
- current amplitude and
- duration as well as
- flow speed of the plasma gases and the shielding gases (**Figure 4201.03.09**).

Macrostructure of VPPA Welds

The shielding gas and its composition used during the VPPA welding of aluminium influences the joint geometry.

The overhead compares the narrow joints produced using 100 % argon with the broader one produced using a mixture of 50 % argon and 50 % helium (**Figure 4201.03.10**).

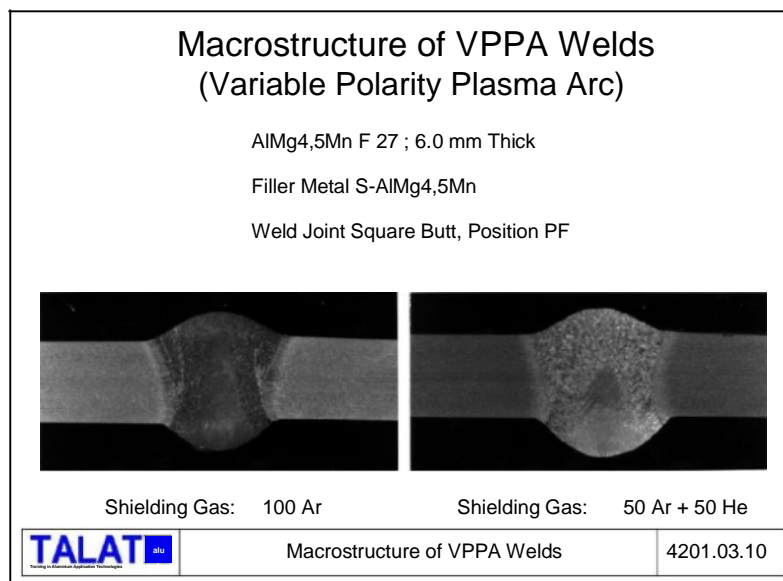

Advantages of Plasma Arc Welding over to TIG Welding

Figure 4201.03.11 compares the plasma arc welding and TIG welding processes, showing the advantages of the former.

Advantages of Plasma Arc Welding over TIG Welding

- * Reliable arc ignition due to pilot arc
- * Stable arc
- * Insensitive to changes in torch-to-work distance
- * Higher welding speeds
- * Less distortion due to narrow HAZ
- * One-sided welding possible also for thicker sheets
- * Controlled through welding using the keyhole technique
- * Less effort required for edge preparation
- * Filler metal not required
- * Deeper penetration
- * Tungsten inclusions avoided

Process Steps of the Plasma Arc Cutting

Plasma arc cutting can be used to cut metals which cannot be cut using the oxyacetylene flame cutting (e.g., Al, Cu, CrNi-steels). The high energy density of the restricted plasma arc and its kinetical energy is utilised in melting and blowing away the molten metal from the cutting groove.

A pilot (auxiliary) arc is drawn between electrode and the gas cup, this arc being transferred to the work when the torch is brought near the work. The plasma gas (a mixture of argon and hydrogen in the ratio 3:2 is usually employed) dissociates and ionises at the incandescent tungsten electrode, streaming with a high kinetical energy through the torch orifice to the work-piece. This energy is converted to heat at the work edges, causing these to melt. The moving gas stream then sweeps away the molten metal leaving a cut groove (**Figure 4201.03.12**). Sheets with a maximum thickness of around 150 mm can be cut (150 kW arc power). More economical cutting solutions are possible, using variations of the process, like the water injection plasma cutting (WIPC).

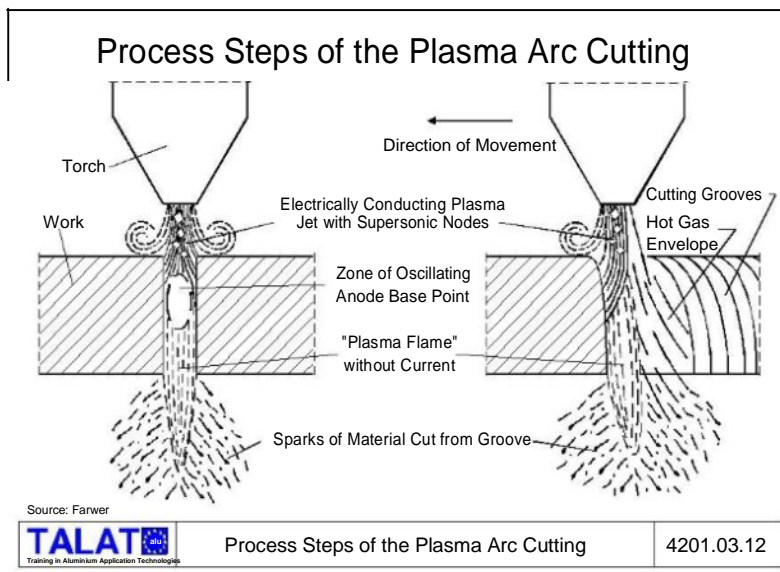

Guide Values for Plasma Arc Cutting

The cutting performance depends on a number of factors, so that the choice of the equipment to be employed is based especially on the economical aspects of the process. Gas costs and the environmental considerations must be considered before procuring the equipment (**Figure 4201.03.13**).

Sheet Thickness mm	Setting-Values				Consumption		Equipment Power		
	Quality Cut		Rough Cut		Cutting Rate mm/min	Ar-gon Hydro-gen l/min.	Arc Power kW	Open Circuit Voltage V	Nozzle Dia. mm
	Cutting Current A	Cutting Rate mm/min	Current for Cutting A	Cutting Rate mm/min					
10	120	1600	250	4500	12	8	max.50	400	
20	120/200	900/1200	250	2000	20	10			
30	200	700	250	1200	20	10			1.4
40	200	500	250	700	20	10			
50	200/250	300/400	250	500	25	12			2.5
60	250	250	250	300	25	12			
70	-	-	250	200	25	12			
80	-	-	250	150	25	12			
90	-	-	250	100	25	12			

Source: DVS

TALAT | Guide Values for Plasma Arc Cutting | 4201.03.13

Characteristics which Determine the Quality of a Plasma Arc Cut

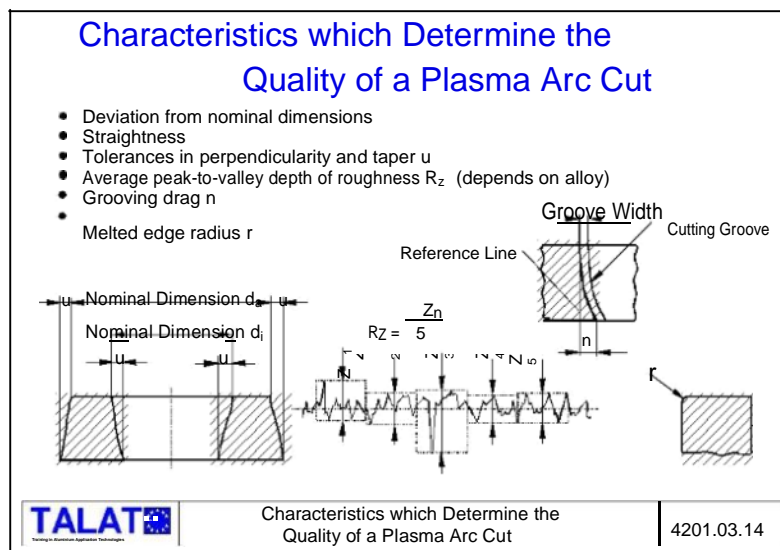

DIN 2310 part 1 lists a number of characteristics which have to be evaluated to judge the quality of cuts produced employing the gas-shielded plasma arc cutting process. One can thus differentiate between form, position and dimensional tolerance on one hand and the cut surface quality on the other (**Figure 4201.03.14**).

4201.04 Metal Inert Gas Welding (MIG)

- Principle of MIG welding
- Guide values for the manual MIG welding
- MIG welded joint profiles as a function of shielding gas and welding parameters
- Influence of contact tube distance on MIG welding current and penetration
- Modifications of MIG welding
- MIG Welding with pulsed current
- Macrostructures of MIG welds
- Guide values for thick-wire MIG welding
- Melting Power of thick-wire MIG welding
- Principle of the narrow-gap MIG welding
- Principle of the plasma-arc MIG welding
- Fields of application for the shielded gas welding of aluminium

Principle of MIG Welding

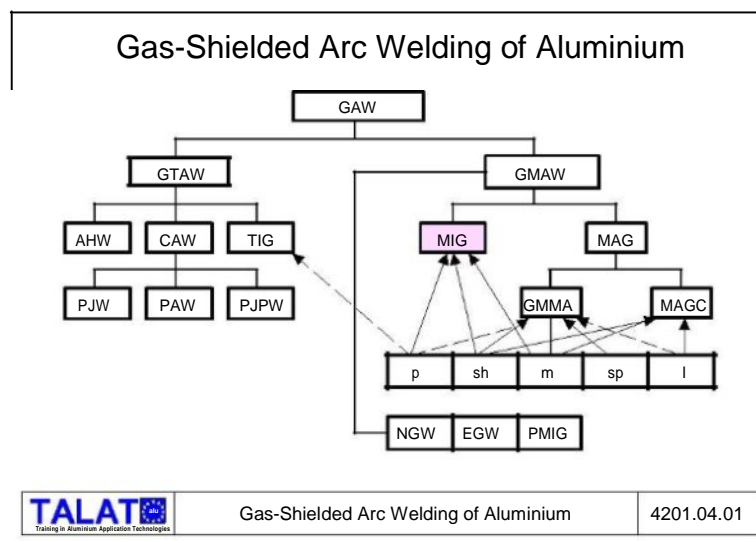

Analogous to TIG welding, MIG welding is conducted using inert gases (**Figure 4201.04.01**). The arc is drawn between the melting wire electrode and the work. The current to the positively poled wire is supplied through a contact nozzle (tip). Here it is possible to work with high current densities ($> 100 \text{ A/mm}^2$). In comparison, the current densities used for TIG welding with alternating current lie around 20 to 30 A/mm^2 (**Figure 4201.04.02**).

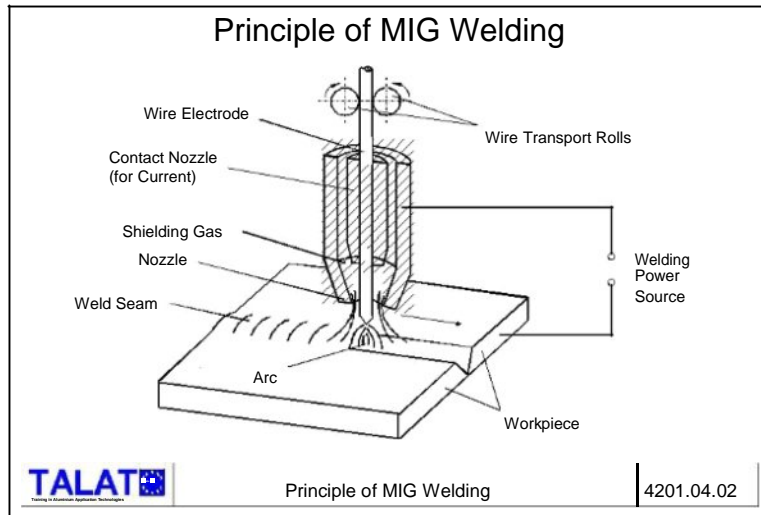

The melting power of MIG welding is thus very much higher than with the TIG process. Contact nozzle and the relatively short wire end are surrounded by inert gas. This gas serves to protect the melt pool, wire and arc as well as to cool the contact nozzle.

The filler wire (0.8 to 2.0 mm diameter) is delivered as rolls and fed to the welding zone with the help of wire feed rolls.

Guide Values for the Manual MIG Welding

Manual MIG welding is usually carried out in the lower power levels (< 400 A) because of the weld pool size, arc radiation and the heat developed. Wire diameters of up to 1.6 mm are used. At higher power levels, fully mechanised or automatic equipment is employed (**Figure 4201.04.03**).

Guide Values for the Manual MIG Welding Process

Work-piece Thickness	Welding Current 1)	Arc Voltage	Wire Electrode Diameter	Welding speed	Argon Consumption 2)	No of Passes
mm	A	V	mm	cm/min	dm ³ /min	
4	180	22	1,2	90	15	1
6	200	23	1,2	80	15	1
8	240	23	1,2	75	16	1
10	260	24	1,6	70	18	2
15	270	24	1,6	65	20	4 - 6
20	270	24	1,6	60	20	4 - 8
25	280	25	1,6	60	20	4 - 10

1) 10 to 20 % Higher Current for Fillet Welds. Higher Currents for Filler Metal of Type S-AlMg, Lower for Type S-AISi.

2) Use Higher Inert Gas Flow Rate for S-AlMg Fillers than for S-AISi, Helium Consumption about 2.5 to 3 Times Higher than the Values Given here.

TALAT
Training in Advanced Application Technologies

Guide Values for the Manual MIG Welding

4201.04.03

MIG Welded Joint Profiles as a Function of Shielding Gas and Welding Parameters

The penetration during the welding of aluminium depends not only on the current and voltage but also on the composition of the shielding-gas used. This is illustrated in **Figure 4201.04.04** for dummy welds on AlMg5 using a filler wire of the same composition. The most unfavourable conditions occur when pure argon gas is used.

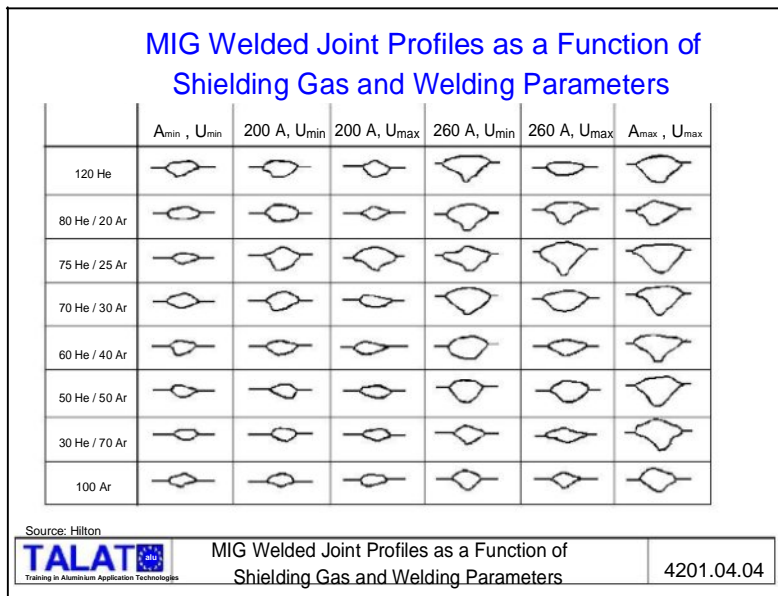

Influence of Contact Tube Distance on MIG Welding Current and Penetration

During steel welding, the penetration and current decrease with increasing contact tube distance.

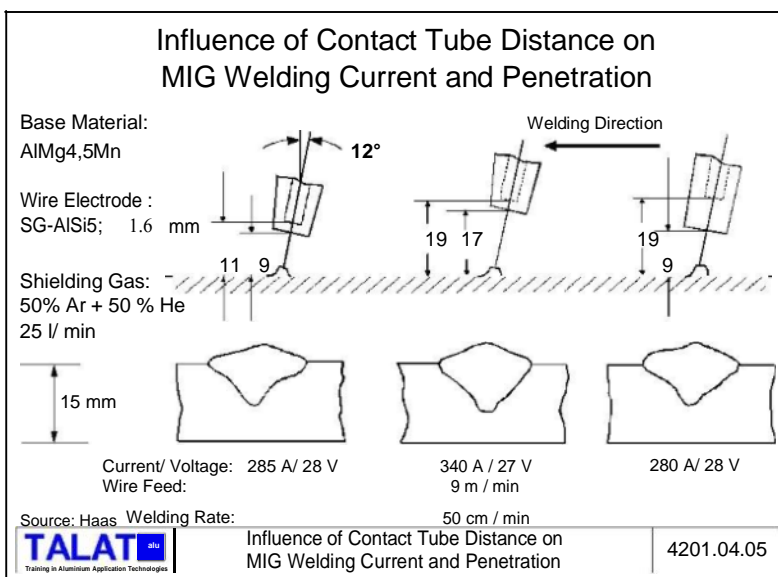

The MIG welding of aluminium shows an opposite behaviour, i.e., current and penetration increase with increasing contact tube distance (**Figure 4201.04.05**). The reason for this diverging behaviour is the different energy conditions existing in the steel and aluminium arcs.

Modifications of MIG Welding

A number of modifications to the MIG welding process have made it possible to diversify the fields of application for this welding process.

Pulsed welding which has a number of advantages is most widely spread:

- a short-circuit-free transfer to the material is possible even for thin sheets (< 4mm).
- stable arc
- degassing is easier in a pulsing bath (lower porosity)
- thicker wires, which have the advantage of a lower ratio of oxidised surface to wire volume, can be used to replace thinner wires.

In thick-wire welding it is possible to employ higher currents.

In high-current welding, thin wires are melted using high current densities.

In narrow-gap welding, thick sheets can be welded without any edge preparation. Because of the narrowness of the gap, less filler metal is required. This leads to a decreased heat development with relatively low distortion.

The plasma-MIG welding is a process combination in which a plasma arc and a MIG arc are established simultaneously.

In MIG spot welding, overlapping sheets are melted in local spots (**Figure 4201.04.06**).

Modifications of MIG Welding		
- MIG welding with pulsed current (Pulsefrequency can be varied smoothly)		
- MIG thick-wire welding (Wire diameter 3.2 to 6.0 mm; 400 to 800 A)		
- MIG high-current welding (Wire diameter 1.2 mm; 400 A; ≤ 32 mm single pass; square butt)		
- MIG narrow-gap welding (Web distance 6 to 9 mm; 2 special wire electrode arrangements)		
- Plasma MIG welding (similar to plasma arc welding; better penetration)		
- MIG spot welding (Producing overlapped joints; special torches)		
 TALAT <small>Training in Aluminum Application Technologies</small>	Modifications of MIG Welding	4201.04.06

MIG Welding with Pulsed Current

Using a thyristor power source for the pulsed MIG welding, it is possible to vary the frequency in steps (25, 33 1/3, 50 and 100 Hz).

The frequency of current from modern transistorised power sources can be varied continuously up to 300 Hz.

The process is based on the principle, that the overlaid pulse enhances the pinch effect, causing the molten metal droplet (bead) to fall from the wire electrode. A strong current pulse is overlaid on the basis current, the latter being required to maintain a stable arc.

The current exceeds a certain critical value, making a short-circuit-free transfer of material possible. The heat input can thus be ideally controlled to suit the base and filler materials. Material overheating and spray formation is almost nonexistent (**Figure 4201.04.07**).

Even thin sheets can be welded with thick wire electrodes. The well-known transport problems with aluminium wires can be avoided.

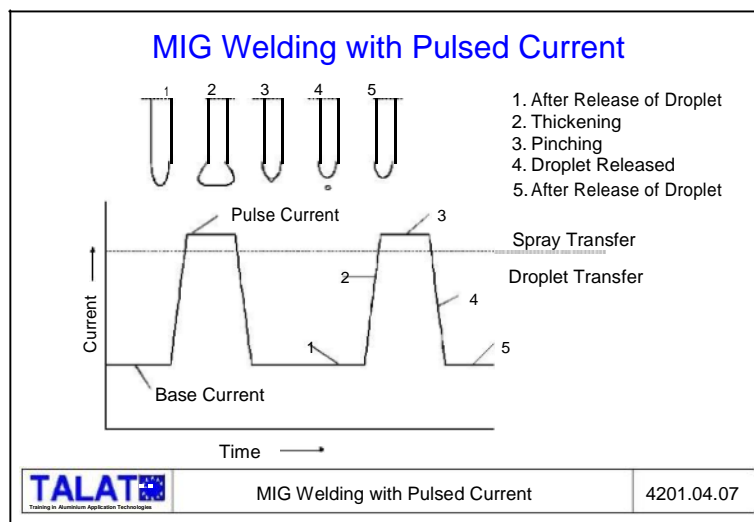

Macrostructure of MIG Welds

Figure 4201.04.08 clearly shows that even in pulse welding the typical behaviour of shielding gas employed is observed here also. The higher energy input of helium produces broader and flatter welds.

Macrostructure of MIG Welds

AlMg4,5Mn F27; 2.5 mm thick; Filler S-AlMg4,5Mn;
Weld Joint Square Butt; Position PA

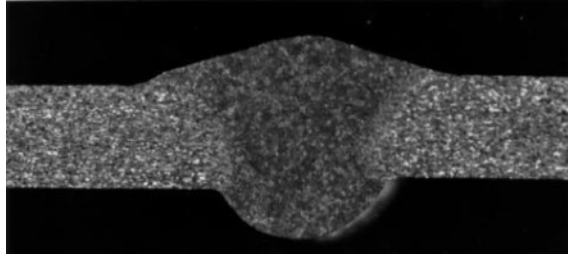

Pulsed Welding 100 Ar

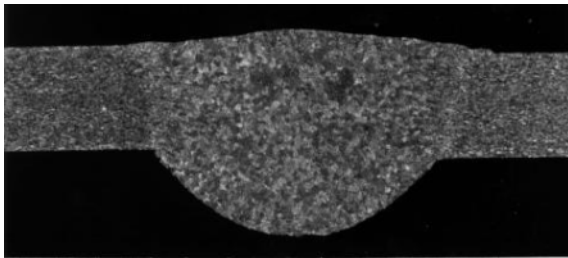

Pulsed Welding, 50 Ar +50 He

Guide Values for Thick-Wire MIG Welding

Thick sheets with or without joint gaps can be welded and capped using thick-wire MIG welding.

Sheets up to 30 mm thick can be welded using an argon-helium mixture (**Figure 4201.04.09**).

Guide Values for Thick-Wire MIG Welding

Sheet Thickness mm	Wire electrode Dia mm	Welding Current A	Welding Speed cm/min	Shielding Gas Consumption l/min	Joint Form, Web Height No. of Passes
25	4	1st Pass 450 Cap Pass 500	25	Argon 46 l/min	Double Y Joint, 70 ° 4 mm Web Height Pass + Cap Pass
25	4.8	1st Pass 500 2nd Pass 500	30	Argon 46 l/min	Double Y Joint, 70 ° 3 mm Web Height Pass + Cap Pass
50	4	1st to 4th Pass 550	25	75 % He 25 % Ar 105 l/min	Double Y Joint, 70 ° 4 mm Web Height Pass + Cap Pass + 1 Cover Pass Each
50	4.8	1st Pass 750 2nd Pass 550	32	75 % He 25 % Ar 55 l/min	Double Y Joint, 90 ° 26 mm Web Height Pass + Cap Pass
75	5.6	1st to 6th Pass 650	25	75 % He 25 % Ar 55 l/min	Double U Joint, 30 ° 6.5 mm Web Height Pass + Cap Passes Each

Deposit Efficiency of Thick-Wire MIG Welding

With the high currents employed here, melting powers of 10 kg/h and higher can be attained. The current density existing in the thinner wires can be more than twice as large as the current density for thicker wires (**Figure 4201.04.10**).

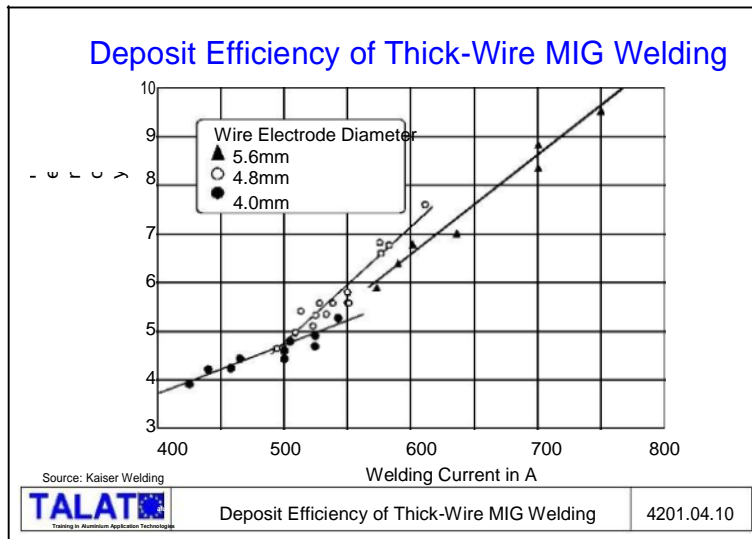

Principle of the Narrow-Gap MIG Welding

Special water-cooled wire electrode feeding mechanisms are required for the narrow-gap MIG welding. A melting of the joint edges is guaranteed by a suitable bending of the wire or by oscillation (weaving).

A number of passes can be applied simultaneously by using a tandem arrangement (**Figure 4201.04.11**).

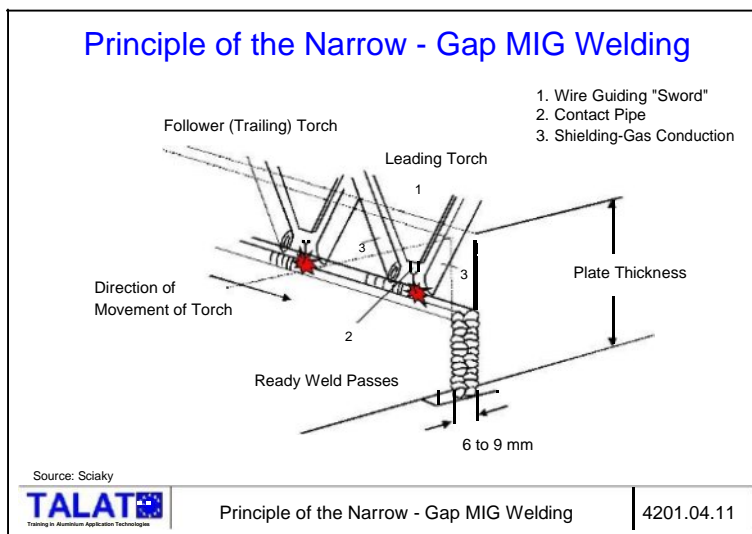

Principle of the Plasma-Arc MIG Welding

The melting power of the MIG welding arc is increased by adding a plasma arc to it.

The plasma arc preheats the work and wire, thus avoiding cold-shut defects at the start of the weld. The "hot" wire can be fed at a higher rate producing a higher melting performance (**Figure 4201.04.12**). With this method, square butt joints can be made even in thicker sheets.

Large-sized torches are required for this combined process, making a manual welding impossible.

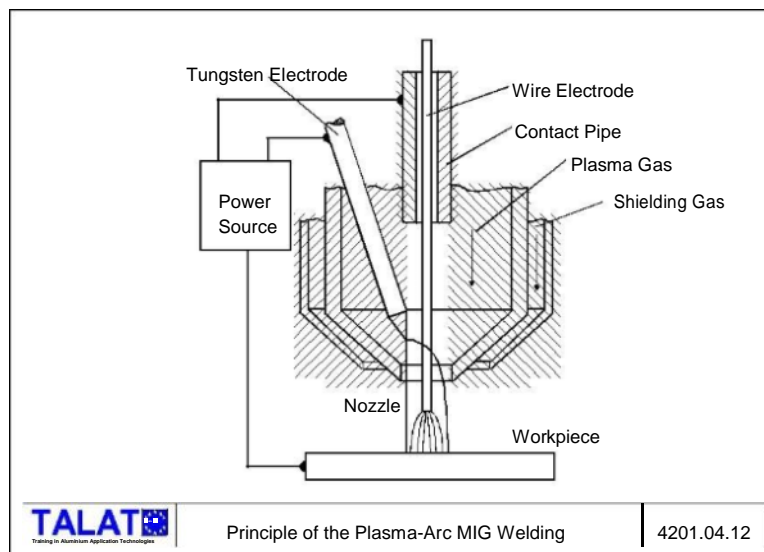

Fields of Application for the Shielded Gas Welding of Aluminium

A comparison of the common processes for welding aluminium shows that MIG welding is employed for thicknesses greater than 2 to 3 mm. TIG welding is employed for lower thicknesses. With the micro plasma arc welding, currents lower than 1 A can be utilised, making it possible to weld thin sheets and foils (**Figure 4201.04.13**).

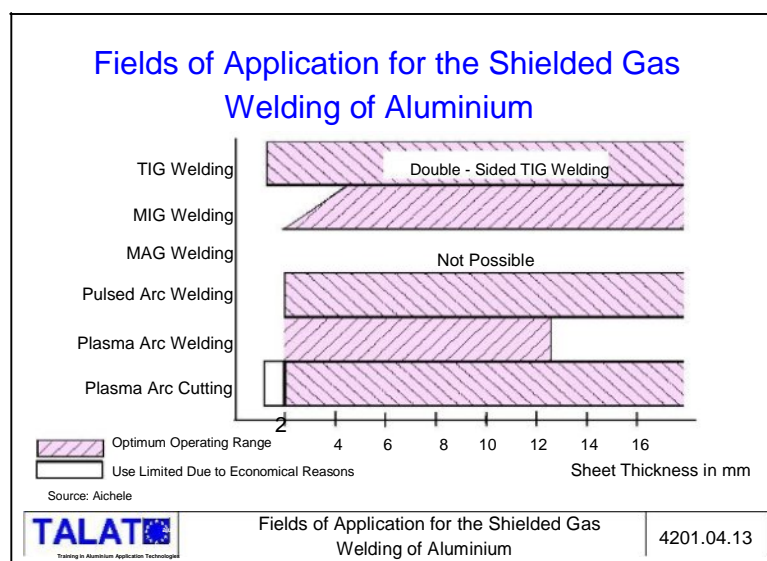

4201.05 Literature/References

1. - Aluminium-Taschenbuch, 14. Auflage, 1984, Aluminium-Verlag, Düsseldorf
2. - Wolfram-Schutzgasschweißen, Lehrgangsmappe der AG SP des DVS, Deutscher Verlag für Schweißtechnik, Düsseldorf
3. - Metall-Schutzgasschweißen, Lehrgangsmappe der AG SP des DVS, Deutscher Verlag für Schweißtechnik, Düsseldorf
4. Killing, R.: Handbuch der Schweißverfahren, Teil 1: Lichtbogenschweißverfahren, Fachbuchreihe Schweißtechnik Bd. 76, Deutscher Verlag für Schweißtechnik, 1991, Düsseldorf
5. Aichele, G.: Schutzgasschweißen, Verfahren, Anwendung, Wirtschaftlichkeit, Messer- Griesheim GmbH; Informationsabteilung
6. Haas, B.: Schutzgasschweißen von Aluminium und seinen Legierungen, Schweizer Aluminium Rundschau 32 (1982), H. 5
7. Hilton, D. E.: He/Ar gas mixtures prove more economic than Argon for Al welds, Weld. and Met. Fabric. (1982) H.6, p. 232/240
8. Tomsic, M.und Barhorst, S.: Keyhole Plasma Arc Welding of Aluminium with variable polarity power, Weld. J. (1984), H. 2, p 25/32
9. - Welding Kaiser Aluminium, Kaiser Aluminium & Chemical Sales Inc., Kaiser Center, Oakland, California, 1978
10. EN 439 „Schutzgase zum Lichtbogenschweißen und Schneiden“

4201.06 List of Figures

Figure No.	Figure Title (Overhead)
4201.01.01	Gas-Shielded Arc Welding of Aluminium
4201.02.01	Principle of TIG Welding
4201.02.02	TIG Welding Equipment
4201.02.03	Watercooled TIG Welding Torch
4201.02.04	Torch Forms for TIG Welding
4201.02.05	Shielding Gases for Welding and Cutting
4201.02.06	Flow Meters
4201.02.07	Flow Meters for Torches

Figure No.	Figure Title (Overhead)
4201.02.08	Effect of Current and Inert Gas
4201.02.09	Argon Consumption for TIG Welding
4201.02.10	Tungsten Electrodes for TIG Welding
4201.02.11	Influence of Current Type on Weld Pool
4201.02.12	Arc Burning with Alternating Current
4201.02.13	Action of Alternating Current during TIG Welding of Aluminium
4201.02.14	Function of Filter Condenser
4201.02.15	TIG Welding with Pulsating Square-Wave Alternating Current
4201.02.16	TIG Alternating Current Welding Parameters
4201.02.17	Current Loading of Tungsten Electrode
4201.02.18	Manual and Mechanised TIG Welding
4201.02.19	Macrostructure of TIG Weldings
4201.03.01	Gas-Shielded Arc Welding of Aluminium
4201.03.02	Principle of Plasma Arc Welding
4201.03.03	Arc Form during TIG and Tungsten Plasma-Arc Welding
4201.03.04	Weld Pool Form and Heat Affected Zone
4201.03.05	Varying Arc Stabilities
4201.03.06	Principle of the Keyhole Plasma Arc Welding
4201.03.07	Guide Values for the Positive Polarity Plasma Arc Welding
4201.03.08	Principle of the VPPA Welding (Variable Polarity Plasma Arc)
4201.03.09	Guide Values for the VPPA Welding
4201.03.10	Macrostructure of VPPA Welds
4201.03.11	Advantages of Plasma Arc Welding over TIG Welding
4201.03.12	Process Steps of the Plasma Arc Cutting
4201.03.13	Guide Values for Plasma Arc Cutting
4201.03.14	Characteristics which Determine the Quality of a Plasma Arc Cut
4201.04.01	Gas-Shielded Arc Welding of Aluminium
4201.04.02	Principle of MIG Welding
4201.04.03	Guide Values for the Manual MIG Welding
4201.04.04	MIG Welded Joint Profiles as a Function of Shielding Gas and Welding Parameters
4201.04.05	Influence of Contact Tube Distance on MIG Welding Current and Penetration
4201.04.06	Modifications of MIG Welding
4201.04.07	MIG Welding with Pulsed Current
4201.04.08	Macrostructure of MIG Welds
4201.04.09	Guide Values for Thick-Wire MIG Welding
4201.04.10	Deposit Efficiency of Thick-Wire MIG Welding
4201.04.11	Principle of the Narrow-Gap MIG Welding
4201.04.12	Principle of the Plasma-Arc MIG Welding
4201.04.13	Fields of Application for the Shielded Gas Welding of Aluminium